

# **BEFCO®**

## **Operator's Manual**

### **GREEN-RITE**

**One Pass Overseeder-Aerator and/or Seeder-Cultivator  
with Corrugated Roller for Lawn and Turf Operations**

**GRT-250, GRT-258, GRT-266, GRT-282**

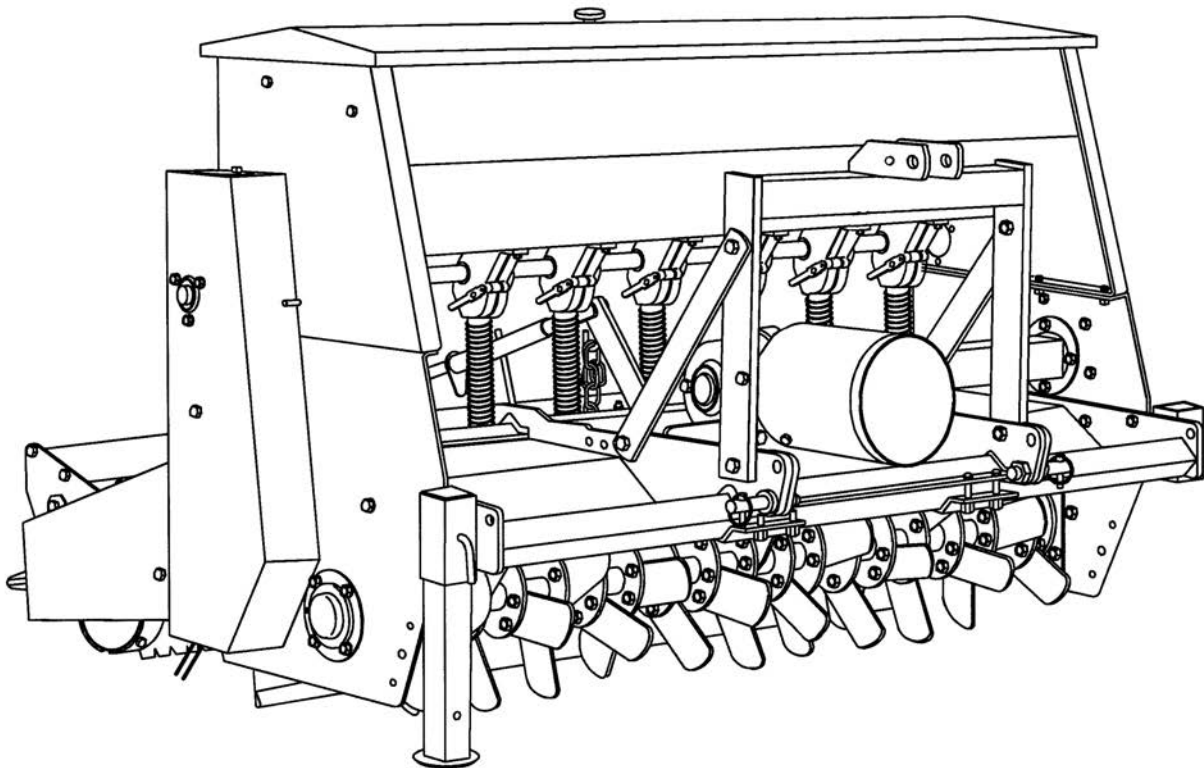

The operator's manual is a technical service guide and must always accompany the machine.

**Manual 971-130B**

**April 2023**

# SAFETY

Take note! This safety alert symbol found throughout this manual is used to call your attention to instructions involving your personal safety and the safety of others. Failure to follow these instructions can result in injury or death.



*This symbol means:  
ATTENTION!  
BECOME ALERT!  
YOUR SAFETY IS INVOLVED!*

## Signal Words

Note the use of the signal words DANGER, WARNING and CAUTION with the safety messages. The appropriate signal words for each have been selected using the following guidelines:



**DANGER:** Indicates an imminently hazardous situation that, if not avoided, will result in death or serious injury.



**WARNING:** Indicates a potentially hazardous situation that, if not avoided, could result in death or serious injury, and includes hazards that are exposed when guards are removed. It may also be used to alert against unsafe practices.



**CAUTION:** Indicates a potentially hazardous situation that, if not avoided, may result in minor or moderate injury.

# INDEX

<b>1 - GENERAL INFORMATION</b>	4
1.01 - General	4
1.02 - Warranty Information	4
1.03 - Model and Serial Number ID	5
<b>2 - SAFETY PRECAUTIONS</b>	6
2.01 - Preparation	6
2.02 - Starting and Stopping	7
2.03 - Messages and Signs	7
<b>3 - OPERATION</b>	10
3.01 - Operational Safety	10
3.02 - Set Up	12
3.03 - Rear Tailgate Adjustment	13
3.04 - Tickler Tine Adjustment	13
3.05 - Corrugated Roller Adjustment	14
3.06 - Front Roller Adjustment	15
3.07 - Front Wheels Adjustment	16
3.08 - Hopper Adjustment	16
3.09 - Seed (or Fertilizer) Hopper Calibration	18
3.10 - Seed Conveyor Kit	20
3.11 - Driveline	20
3.12 - Safety Slip Clutch	22
3.13 - Pre-Operational Check	22
3.14 - Attaching to the Tractor	23
3.15 - Start Up	25
3.16 - Test Run	26
3.17 - Working Depth	26
3.18 - Working Speed	27
3.19 - Headland Procedure	27
3.20 - Working Limitations	27
3.21 - Uneven Terrain	28
3.22 - Transporting	28
<b>4 - MAINTENANCE</b>	31
4.01 - Maintenance Safety	31
4.02 - Service	32
4.03 - Changing Rotors	34
4.04 - Blade Maintenance	35
<b>5 - REPAIR PROCEDURES</b>	37
5.01 - Gearbox	37
5.02 - Rotor Chain Case	37
5.03 - Removing the Rotor	37
5.04 - Hopper Transmission Chain Case	38
5.05 - Suggested Spare Parts	39
5.06 - Storage	40
<b>6 - TROUBLESHOOTING</b>	41
<b>7 - PRE-DELIVERY CHECKLIST</b>	43
<b>8 - WARRANTY</b>	44

# 1 - GENERAL INFORMATION

Thank you and congratulations for having chosen our implement. Your new Green-Rite is a technologically advanced machine constructed of high quality, sturdy components that will fulfill your working expectations.

The Green-Rite is the ideal machine for sport fields, parks, golf courses, airports, turf farm operations and anywhere the combination of lower labor costs and a professionally finished job is essential.

Read this manual carefully. It will instruct you on how to operate and service your implement safely and correctly. Failure to do so could result in personal injury and/or equipment damage.

## 1.01 - General

The implement described in this manual is to be used with tractors with PTO at 540 rpm and clockwise rotation.



**CAUTION:** Always ensure that the coupling of the implement with the tractor is done at the same PTO speed and direction of rotation. Do not operate this implement at a PTO speed or direction of rotation other than that shown on the implement. Serious damage can occur to the machine and/or the operator.



**CAUTION:** Unless otherwise specified, all hardware is metric. Use only metric tools on metric hardware. Other tools that do not fit properly can slip and cause injury.



**CAUTION:** Right hand and left hand sides of the implement are determined by facing in the direction the implement will travel when going forward (see fig. 2).

## 1.02 - Warranty Information

Carefully read the Warranty section<sup>1</sup>, detailing coverage and limitations of this warranty. **Warranty** is provided for customers who operate and maintain their equipment as described in this manual. Warranty registration is accomplished by the dealer by completing and forwarding the **Warranty Registration** form to the Company, along with a copy of the dealer's invoice. It is in your best interest to insure that this has been done.

---

<sup>1</sup> See Chapter 8 - Warranty.

Warranty does not cover the following:

1. Cleaning, transporting, mailing and service call charges.
2. Normal wear items such as belts, blades, bearings, drivelines, shear pins, slip clutches, etc.
3. Depreciation or damage caused by normal wear, accidents, improper maintenance, improper protection or improper use.
4. The use of non-original spare parts and accessories.

Your Authorized Company Dealer has genuine parts in stock. Only these approved replacement parts should be used.

This limited warranty covers defective material and workmanship. The cost of normal maintenance or repairs for accidents or improper use and related labor will be borne by the owner.

### 1.03 - Model and Serial Number ID

Attached to the frame is an ID plate showing the model and the serial number. Record your implement model and serial number in the space provided below. Your dealer needs this information to give you prompt, efficient service when you order parts.

<b>BEFCO</b>	1781 S. Wesleyan Blvd. – P.O. Box 6036 Rocky Mount, N.C. 27802 – U.S.A. Tel: 1.252.977.9920 Fax: 1.252.977.9718
<b>MODEL:</b>	
<b>SERIAL:</b>	
<b>VERSION:</b>	

## 2 - SAFETY PRECAUTIONS

Safety is the primary concern in the design and manufacture of our products. Unfortunately our efforts to provide safe equipment can be wiped out by a single careless act of an operator.

In addition to the design and configuration of equipment, hazard control and accident prevention are dependent upon the awareness, concern, prudence and proper training of personnel involved in the operation, transport, maintenance and storage of equipment. It is the operator's responsibility to read and understand all safety and operating instructions in the manual and to follow these.

Allow only properly trained personnel to operate the implement. Working with unfamiliar equipment can lead to careless injuries. Read this manual, and the manual for your tractor, before assembly or operation, to acquaint yourself with the machines. It is the implement owner's responsibility, if this machine is used by any person other than yourself, is loaned or rented, to make certain that the operator, prior to operating, reads and understands the operator's manuals and is instructed in safe and proper use.

### 2.01 - Preparation



1. Before operating equipment read and understand the operator's manual and the safety signs (**see fig. 2**).
2. Thoroughly inspect the implement before initial operation to assure that all packaging materials, i.e. wires, bands, and tape have been removed.
3. Personal protection equipment including hard hat, safety glasses, safety shoes, and gloves are recommended during assembly, installation, operation, adjustment, maintaining and/or repairing the implement.
4. Operate the implement only with a tractor equipped with an approved Roll-Over-Protective-System (ROPS). Always wear your seat belt. Serious injury or even death could result from falling off the tractor.
5. Clear area of stones, branches or other debris that might be thrown, causing injury or damage.
6. Operate only in daylight or good artificial light.
7. Ensure the implement is properly mounted, adjusted and in good operating condition.
8. Ensure that all safety shielding and safety signs are properly installed and in good condition.
9. Consult local utility companies to make certain there are no buried gas lines, electrical cables, etc., in the work area before beginning operation.

## 2.02 - Starting and Stopping



1. Be sure that no one is near the machine prior to engaging or while the machine is working.
2. Be sure the tractor is in "Neutral" before starting engine.
3. Equipment operating power is supplied from tractor PTO. Refer to your tractor manual for PTO engagement and disengagement instructions. Always operate PTO at 540 rpm. Know how to stop the tractor and implement quickly in case of an emergency.
4. When engaging PTO, the engine rpm should always be low. Once engaged and ready to start cutting, raise PTO speed to 540 rpm and maintain throughout cutting operation.
5. Check the tractor master shield over the PTO stub shaft. Make sure it is in good condition and fastened securely to the tractor. Purchase a new shield if old shield is damaged or missing.
6. After striking an obstacle, disengage the PTO, shut the tractor down and thoroughly inspect for damage before restarting.
7. Never engage the PTO until the implement is in the down position and resting on the ground. Never raise the implement until the rotor has come to a complete stop.
8. To park the vehicle safely, stop vehicle on a level surface (not on a slope), disengage PTO, engage the parking brake, stop the engine, remove the key, and wait for engine and all moving parts to stop before leaving the operator's seat.
9. Stay clear of rotating drivelines. Entanglement in rotating driveline can cause serious injury or death. Wear close fitting clothing. Stop the engine and be sure PTO driveline is stopped before getting near it.

## 2.03 - Messages and Signs



1. Read and adhere to all safety and operating decals on this machine (**see fig. 2**).
2. Before dismounting tractor: Allow moving parts to stop, stop engine, set brake and remove the key of unattended equipment.
3. Keep away from rotating blades and driveline.
4. Keep guards and shields in place and in good condition.
5. Do not use with bystanders in area.
6. Allow no riders on tractor or implement.
7. Allow moving parts to stop before repair.
8. Securely support implement before working underneath.

Additional warning and operating decals are available at no extra charge. Please specify model and serial number when ordering.

Fig. 2 - Safety decals - implement; replace immediately if damaged.

**⚠ WARNING**

**Falling hazard**

- Do not stand on machine.
- Machine should never be loaded while standing on roller.
- Machine should only be loaded while standing on firm ground.

Failure to follow these instructions could result in serious injury.

950-3438

left side

right side

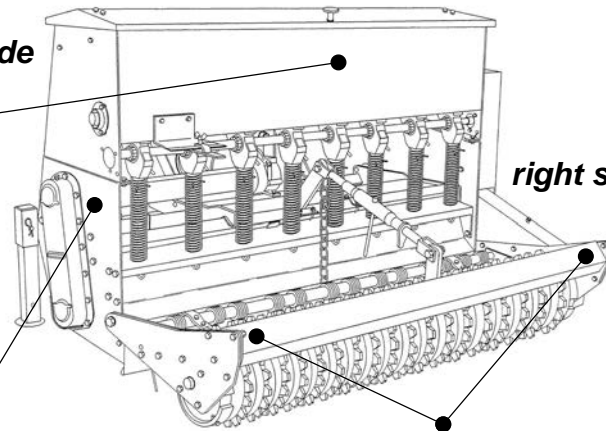

**⚠ DANGER**

Replace shields before using machine

950-2126



Red reflective decal

left side

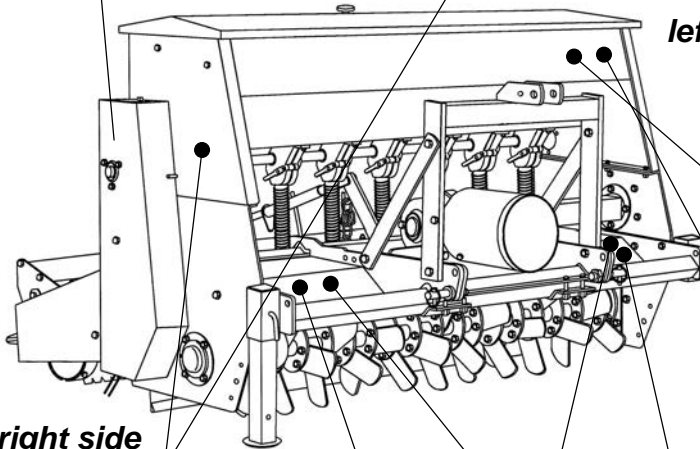

**⚠ DANGER**

**Avoid injury from PTO**

- Entanglement can cause serious injury or death.
- Keep driveline shields in place & in good condition.
- Keep hands, feet and clothing away.
- Operate only with 540 RPM.

950-1098

right side

**⚠ DANGER**

**Moving parts hazard**  
To prevent serious injury or death from moving parts:

- Keep away! Moving parts can crush and dismember.
- Do not operate without guards and shields in place.
- Disconnect and lockout power source before adjusting and servicing.

950-4889

**⚠ CAUTION**

To avoid serious injury:

- Read Operator's Manual before operating, servicing or repairing equipment. Follow all safety rules and instructions. (Manuals are available from your selling dealer.)
- Never allow riders.
- Keep bystanders away from equipment during operation.
- Operate from tractor seat only.
- Keep all shields in place and in good condition.
- Lower equipment to ground, stop engine, remove key and set brake before dismounting tractor.
- Never allow children or untrained persons to operate equipment.
- If equipped, parking stands must be functional, kept in good repair, and stored on the unit. Park and store on a hard, level surface.

950-4178

**⚠ DANGER**

**Rotating blades hazard**  
To prevent serious injury or death:

- Keep hands, feet, hair and clothing away from moving parts.
- Do not go under frame when blades are turning or engine is running. Keep others away.
- Disconnect and lockout power source before adjusting or servicing.

Blade contact can cause serious injury or death

950-2008

**⚠ DANGER**

**Crushing hazard**

To prevent serious injury or death from crushing:

- Never attempt to perform service maintenance without properly blocking up machine.

950-3428



**Safety decals - driveline; replace immediately if damaged.**

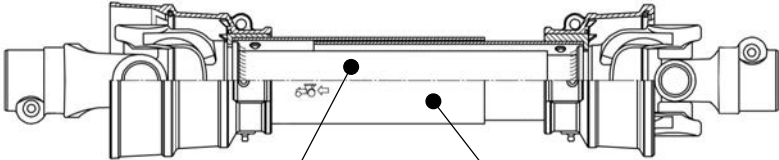

*placed on outer tube*



*placed on outer shield*

## 3 - OPERATION

The Green-Rite is a one pass tool which aerates, seeds (or broadcasts fertilizes), levels, and compacts the soil for improved seed germination.

It consists of an aerator rotor with straight blades on narrowly spaced flanges, powered by the tractor PTO. A large capacity seed hopper with precise metering cups is mounted on the base aerator and broadcasts the seed behind the slicing action of the tines along the entire working width of the machine. Tickler tines follow to help incorporate the seed into the ground through compacted soil and thatch. A corrugated roller with fiberglass rings follows behind the Green-Rite to compact the ground for optimal seed germination.

Depth control wheels with wide garden style thread or a front roller may be quickly mounted to ensure a constant depth over unlevelled terrain.

The Green-Rite comes in working widths of 50", 58", 66" and 82".

A tilling rotor with "C" blades is available upon request, and may be mounted in place of the straight blade aerator rotor. This converts the Green-Rite into a tiller for seed bed preparation which tills, seeds and compacts the soil in a single pass. Changing the machine over from an aerator to a tiller is a simple operation which can be performed in under 30 minutes with a pair of wrenches.

This unique machine reduces costs for ground maintenance of sports fields, parks, highways, hospital grounds, golf courses, etc. The Green-Rite can easily pay for itself within the first few days of use.

### 3.01 - Operational Safety



**CAUTION:** Our machines are designed considering safety as the most important aspect and are the safest available in today's market. Unfortunately, human carelessness can override the safety features built into our machines. Injury prevention and work safety, aside from the features on our aerator-overseeder, are very much due to the responsible use of the equipment. It must always be operated prudently following with great care, the safety instructions laid out in this manual.



1. The use of this equipment is subject to certain hazards which cannot be prevented by mechanical means or product design. All operators of this equipment must read and understand this entire manual, paying particular attention to safety and operating instructions, prior to using.
2. Do not operate the tractor and implement when you are tired, sick or when using medication.

3. Before beginning operation, contact local utility companies to make certain there are no bundled gas lines, electrical cables, etc., in the work area.
4. Keep all helpers and bystanders at least 50 yards from the machine. Only properly trained people should operate this machine.
5. When this machine is operated in populated areas where thrown objects could injure persons or property, standard equipment safety shielding (which is designed to reduce the possibility of thrown objects) must be installed.
6. The majority of accidents involve entanglements on the driveline, injury of bystanders by objects thrown by the rotating blades, and operators being knocked off the tractor by low hanging limbs and then being run over by the implement. Accidents are most likely to occur with machines that are loaned or rented to someone who has not read the operator's manual and is not familiar with the implement.
7. Always stop the tractor, set brake, shut off the tractor engine, remove the ignition key, lower implement to the ground and allow implement blades to come to a complete stop before dismounting tractor. Never leave equipment unattended with the tractor running.
8. Never place hands or feet under implement with tractor engine running or before you are sure all motion has stopped. Stay clear of all moving parts.
9. Do not reach or place yourself under equipment until it is blocked securely.
10. Do not allow riders on the implement or tractor at any time. There is no safe place for riders.
11. Do not operate unless all personnel, livestock and pets are 50 yards away to prevent injury by thrown objects.
12. Before backing up, disengage the implement and look behind carefully.
13. Install and secure all guards and shields before starting or operating.
14. Keep hands, feet, hair and clothing away from moving parts.
15. This rotary implement is designed for use only on tractors with 540 rpm power take off.
16. Never operate tractor and implement under trees with low hanging limbs. Operators can be knocked off the tractor and then run over by the rotating blades.
17. The rotating parts of this machine have been designed and tested for rugged use. However, they could fail upon impact with heavy, solid objects such as steel guard rails and concrete abutments. Such impact could cause the broken objects to be thrown outward at very high velocities. To reduce the possibility of property damage, serious injury, or even death, never allow the cutting blades to contact such obstacles.
18. Frequently check implement blades. They should be sharp, free of nicks and cracks and securely fastened.
19. Stop implement immediately upon striking an obstruction. Turn engine off, remove key, inspect and repair any damage before resuming operation.
20. Stay alert for holes, rocks and roots in the terrain and other hidden hazards. Keep away from drop-offs.
21. Use extreme care and maintain minimum ground speed when transporting on hillside, over rough ground and when operating close to ditches or fences. Be careful when turning sharp corners.

22. Reduce speed on slopes and sharp turns to minimize tipping or loss of control. Be careful when changing directions on slopes. Do not start or stop suddenly on slopes. Avoid operation on steep slopes.
23. When using a unit, a minimum 20% of tractor and equipment weight must be on tractor front wheels. Without this weight, tractor could tip over, causing personal injury or death. The weight may be attained with a front end loader, front wheel weights, ballast in tires or front tractor weights. When attaining a minimum 20% of tractor and equipment weight on the front wheels, you must not exceed the ROPS weight certification. Weigh the tractor and equipment. Do not guess or estimate!
24. Inspect the entire machine periodically<sup>2</sup>. Look for loose fasteners, worn or broken parts, and leaky or loose fittings.
25. Use only the driveline supplied with the implement. Do not use it if it is missing any shield or safety protection.
26. Pass diagonally through sharp dips and avoid sharp drops to prevent "hanging up" tractor and implement.
27. Avoid sudden starts and stops while traveling up or downhill.
28. Always use down slopes; never across the face. Avoid operation on steep slopes. Slow down on sharp turns and slopes to prevent tipping and or loss of control.

### 3.02 - Set Up

**Notice to dealer:** Pre-delivery setup and service including lubrication is the responsibility of the authorized dealer. It is up to him to assure that the machine is in perfect condition and ready to be used. It is his responsibility to ensure that the customer is aware of all safety aspects and operational procedures for the implement. He must also fill out the Pre-Delivery Checklist<sup>3</sup> prior to delivering the implement.



**CAUTION: Stand clear of bands when cutting as they could be under sufficient tension to cause them to fly loose. Take care in removing bands and wire. They often have extremely sharp edges and cut very easily.**

Although the machine usually arrives set up, ready to use, it is important to check certain aspects of the machine before using it. Adjustments are normally necessary in order to adapt the Green-Rite to work under a given condition.

Check the oil in the gearbox. The proper level should be half full. Use 90W gear oil. Make sure the breather cap is clear and tight in the gearbox.

Check all hardware for tightness, especially the bolts holding the 3 point hitch<sup>4</sup>.

Grease the cross and bearings and the telescopic tubes of the driveline.

Ensure that the drive chains are well greased, both the tiller drive chain in the chain housing on the left side (**see fig. 17**) as well as the roller chain which drives the hopper

<sup>2</sup> See Chapter 4 - Maintenance.

<sup>3</sup> See Chapter 7 - Pre-Delivery Checklist.

<sup>4</sup> See Table 4, page 30.

on the right side of the machine (see fig. 16). Both drive chains are supplied with an automatic chain tensioner.

Grease the rotor support (see fig. 16).

Make sure the hopper and seed cups are mounted correctly.

### 3.03 - Rear Tailgate Adjustment

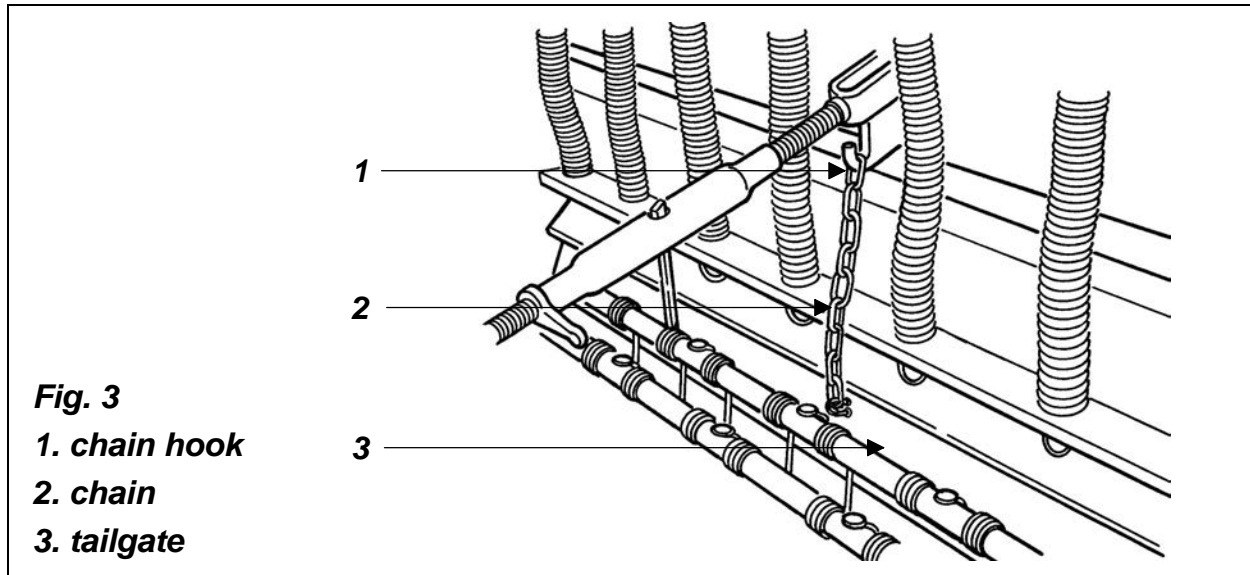

The rear tailgate is especially important when using the tilling rotor in place of the straight blade aerating rotor. Its purpose is to improve the pulverization of the soil as it is tilled. It can be adjusted in various positions with the chain. The closer the tailgate is to the rotor the more pulverized the soil will be. The rear tailgate also works as a shield to prevent dirt and other objects from being thrown (see fig. 3).

### 3.04 - Tickler Tine Adjustment

The Green-Rite comes with two rows of tickler tines mounted between the roller arms (see fig. 4). These tines work as a rake to help cover grass seed for ideal germination conditions. The tines are raised and lowered automatically as the roller follows the contour of the ground.

The roller arms have two set positions to increase or decrease the tickler tine pressure. When the tine holder is positioned in the lower hole the pressure is increased, the top hole decreases the pressure. Always be sure both the right side and the left side are in the same holes.

The tine holder bars can also be swiveled to increase or decrease the pressure of the tines. This also enables you to maintain a consistent pressure and angle as the tines wear. The bars can even be lifted completely up out of the way if the tickler tines are not to be used.

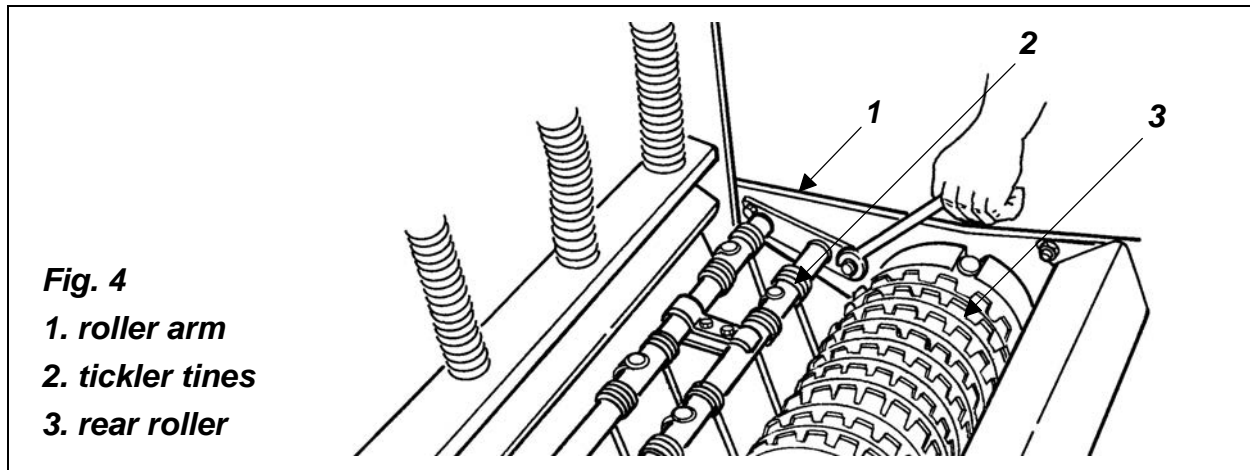
**Fig. 4**

1. roller arm
2. tickler tines
3. rear roller

### 3.05 - Corrugated Roller Adjustment

The rear roller serves the following purposes:

1. Controlling the working depth.
2. Leveling the ground after tilling.
3. Compacting which results in helping bury the material that is distributed. The roller rings help push seed into soil which greatly speeds up and improves germination.

A turnbuckle connected to the frame and to the roller support bar adjusts the working depth of the tines.

By shortening the turnbuckle, the corrugated roller raises thereby lowering the tines to a deeper working depth (**see fig. 5**). Lengthen the turnbuckle lowers the roller which in turn raises the tines to a more shallow working depth.

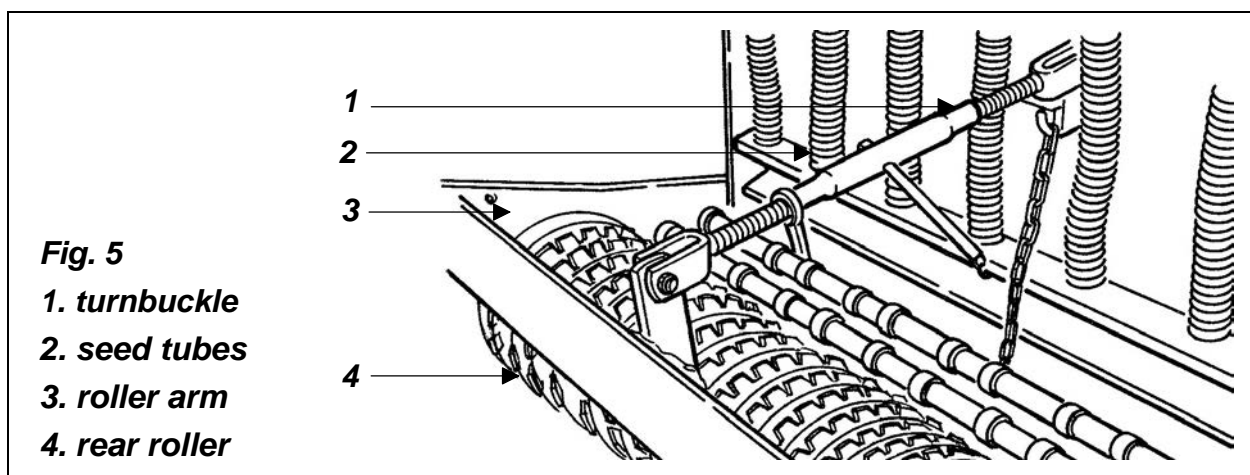
**Fig. 5**

1. turnbuckle
2. seed tubes
3. roller arm
4. rear roller

Under most conditions, the working depth for the **aerating rotor** needs to be between  $\frac{3}{4}$ " and  $1\frac{1}{2}$ " only, but the maximum obtainable depth is 7" or 9" depending on the Green-Rite model.

If the machine is using a **tilling rotor** the working depth needs to be deeper depending on the operator needs. The maximum working depth is 7" or 9" depending on the Green-Rite model.

An adjustable roller-scraper kit is available upon request.



**DANGER:** Stay clear of rotating driveline. Entanglement in rotating driveline can cause serious injury or death. Disengage PTO, engage parking brake or place transmission in "Park", shut off the tractor and remove the key before working around hitch, attaching or detaching driveline, making adjustments, servicing or cleaning the machine.



**DANGER:** Never trust the tractor hydraulics alone to support the machine. Never do any repairs or adjustments under the machine unless it is safely blocked.

### 3.06 - Front Roller Adjustment

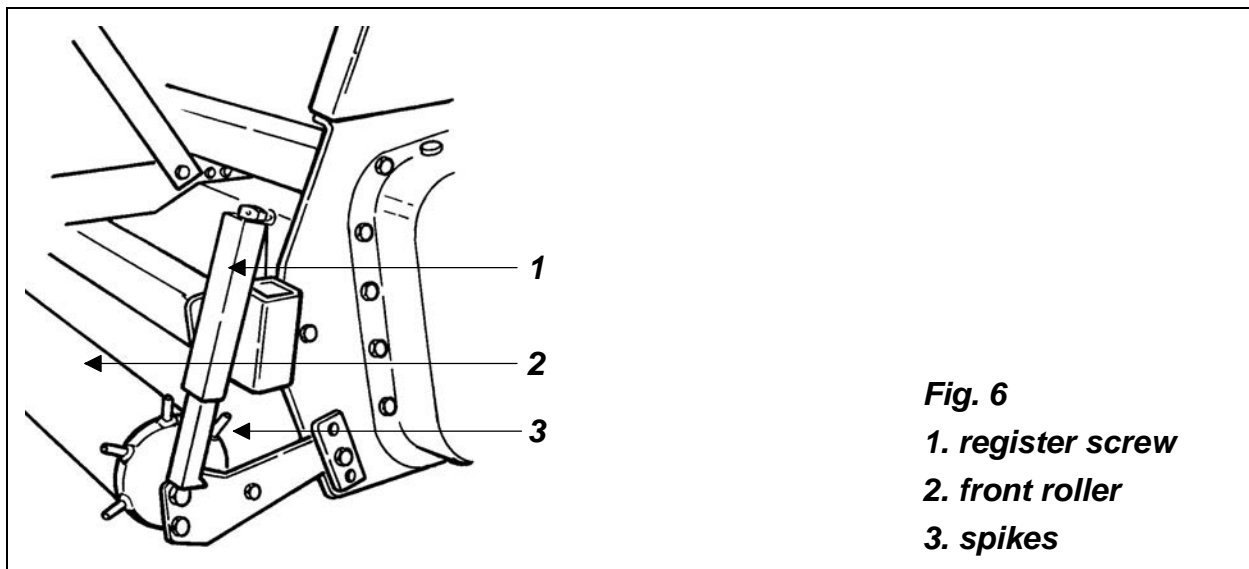

As an option, the Green-Rite can be supplied with a front roller. This option is very useful when the machine is attached to the tractor three point in the float position. This allows the machine to precisely follow the ground contour (**see fig. 6**).

The depth is controlled by turning the register screws attached to each side of the machine. When using, be sure both register screws are in the same position.

The rear roller is then adjusted so the machine is working as level and parallel to the ground as possible. The spikes welded to the front roller ensure constant contact with the ground and prevent the roller from sliding along the ground and bulldozing.

### 3.07 - Front Wheels Adjustment

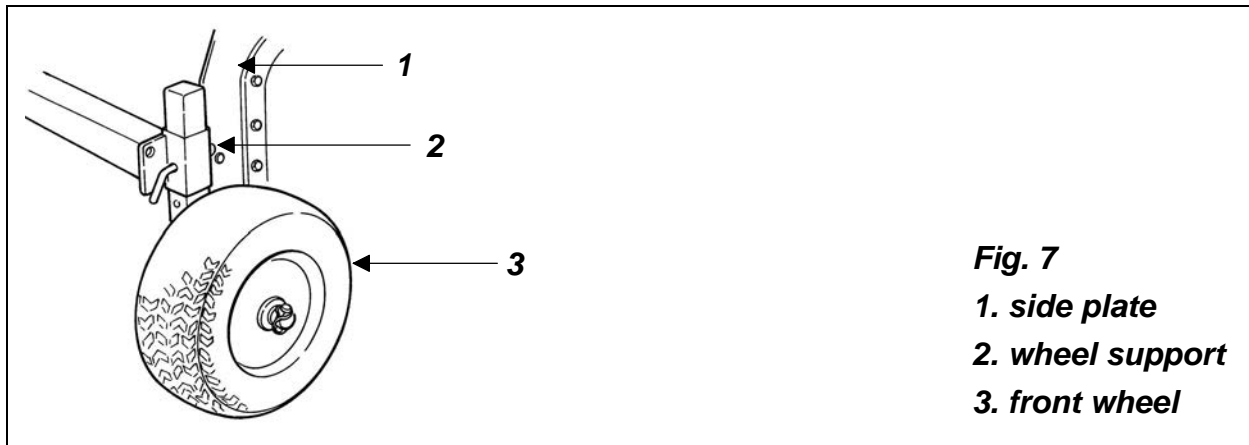

**Fig. 7**

- 1. side plate**
- 2. wheel support**
- 3. front wheel**

Upon request the machine can be adapted with two front depth control gauge wheels (**see fig. 7**) which are mounted on the side wheel support. These wheels have the same function as the front roller, allowing the machine to follow the ground contour. They also should be used with the tractor three point in the float position.

The depth is controlled by raising or lowering the wheels in the wheel supports attached to the side of the Green-Rite. When using, be sure both wheels are in the same position.

The rear roller is then adjusted so the machine is working as level and parallel to the ground as possible.

### 3.08 - Hopper Adjustment

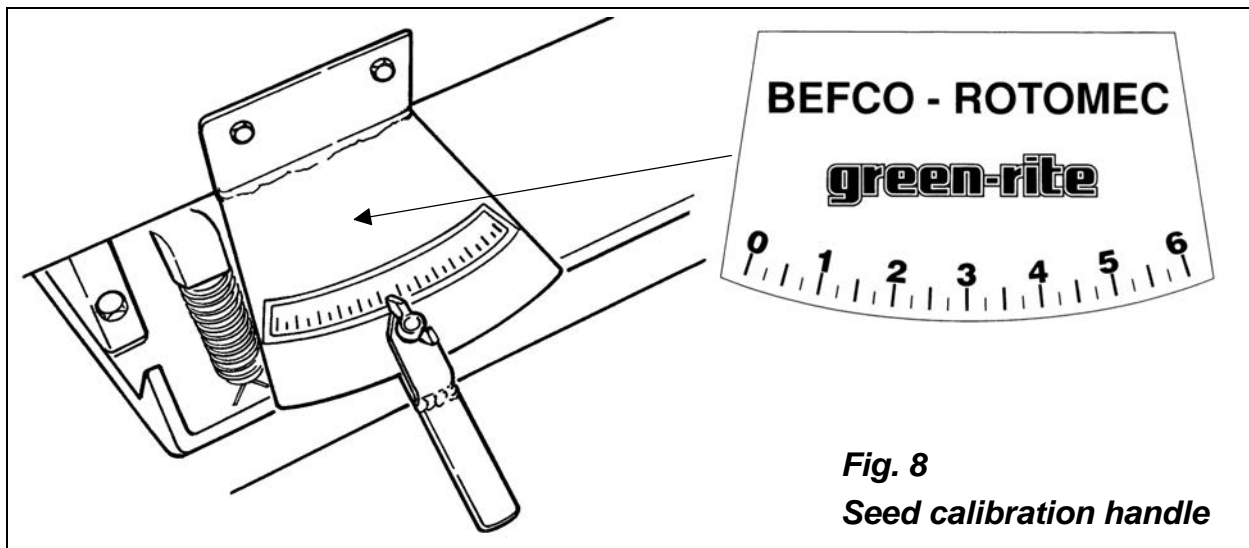

**Fig. 8**

**Seed calibration handle**

The Green-Rite hopper capacities are for the GRT-250 of 4.60 cu.ft., for the GRT-258 of 5.30 cu.ft., for the GRT-266 of 6 cu.ft., and for the GRT-282 of 7.6 cu.ft. The hopper runs the entire width of the machine and has a continuously rotating ground driven



agitator to breakup clods and ensure free flow through the distribution system. On the bottom of the hopper are a certain number of rectangular slots (7, 8, 9 or 11 depending on the width of the Green-Rite) to allow material passage. The **seed cups** mounted under the hopper, which are made entirely of non-corrosive material (nylon and fiberglass), contain an internal gear that rotates inside a housing. A **calibration handle** located on the rear left hand side of the hopper regulates how far to insert the gear inside the housing. The position of the handle, which has a scale from 0 to 6, determines the amount of seed distributed (**see fig. 8**). The seed cups are a force feed system driven by the roller.

The material is held inside the groove of the gear until the groove rotates to the opening at the bottom of the hopper. This rotation is driven by the roller as it moves along the ground. When the handle is in position "0" the gear is completely outside the seed cup and no seed is distributed, with the handle in position "6" the gear is totally inside the cup and distributes at its maximum potential (**see fig. 8**).

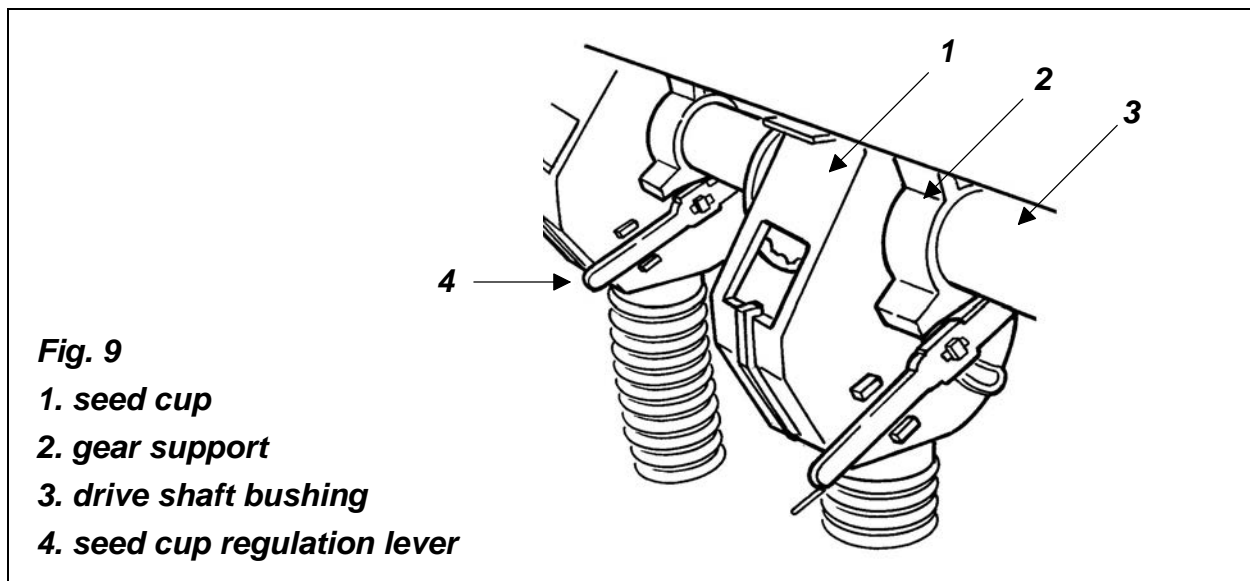

A secondary regulation is the lever located on the side of each cup housing. This controls the position of the gate inside the seed cup (top, middle, bottom and clean out). The positioning of this lever is determined by the size and shape of the material being dispersed (**see fig. 9**). The top position is for the smaller seeds, while the middle and bottom positions are for larger seeds. The clean out position should only be used to flush any remaining seed out of the seed hopper. The seed distribution table values are based on the lever being set in the top position. Typically, most seeds used with this seeder will require you to use the top lever position on the seed cups. If using a larger seed the seed cups are not discharging properly, try using the middle or bottom lever handle positions. Attached to the bottom of each cup is flexible tubing that the material flows through. As the material exits, it hits a split ring which divides the flow until it hits a splash pan and uniformly spreads over the entire working width of the Green-Rite. The hopper is ground driven by the roller which comes with two separate chains with automatic chain tensioners.

Although in essence a broadcast-seeder, the Green-Rite has all the technology to ensure a precise calibrated flow. Being ground driven, the disbursement of the material in the hopper is totally independent from the tractor PTO or the ground speed. The disbursement is regulated solely by adjusting the seed cups levers and the hopper lever.

### 3.09 - Seed (or Fertilizer) Hopper Calibration

There are two adjustments to be made to calibrate the Green-Rite hoppers:

1. The amount of gear inside the seed cup housing.
2. The position of the regulation lever of each individual seed cup.

This system allows use of a wide variety of seeds.

**The output of seed differs greatly depending on their size, density, dampness, and shape.** Other output factors depend on the conditions in which the machine is operating such as, in slick conditions where the roller may slip.

**Table 1** lists the distribution rate in pounds per acre for various seeds that may be used in the Green-Rite. Keep in mind that the hopper and seed cup openings measure in volume and not in weight. Due to the many variables, the distribution rate when using **Table 1** is not always accurate. Only a test run will help determine if the desired amount of seed is being spread.

**TABLE 1 - AMOUNT OF SEED DISTRIBUTED IN LBS/ACRE**

Seed type	Calibration handle position											
	0.5	1	1.5	2	2.5	3	3.5	4	4.5	5	5.5	6
Bentgrass	34	71	89	124	156	182	202	230	251	268	290	306
Bluegrass, Kentucky	18	43	61	81	105	122	138	161	178	194	212	223
Ryegrass, Annual	19	54	79	105	140	166	193	228	254	279	315	341
Ryegrass, Perennial	27	64	92	120	158	187	214	252	281	309	346	375
Fescue, fine blade turf type	16	43	62	83	109	128	149	177	196	215	241	261
Fescue K-31	4	30	52	71	95	114	134	158	176	194	206	210
Clover, White	54	123	176	228	297	350	401	471	523	575	644	697
Clover, Red	51	110	151	194	250	291	334	389	432	474	530	572
Buffalo grass	0	25	43	63	90	109	131	155	176	194	217	224
Bermuda (hulled)	38	87	118	150	193	224	257	300	330	363	406	438
Wheatgrass, Western	7	24	36	48	64	76	89	105	117	130	145	158
Wheatgrass, Crested	14	28	39	48	63	73	84	98	108	119	132	142
Lovegrass, Weeping	68	122	163	200	250	286	325	375	410	448	498	536
Lovegrass, Sand	54	103	139	186	223	259	294	343	380	416	464	500
Alfalfa	43	110	161	213	280	330	382	450	500	551	617	669
Vetch	44	96	140	174	225	265	302	353	393	432	484	523

Use **Table 2 and 3** to determine if the rate you are getting is correct.

There are two ways of setting the calibration on your Green-Rite:

1. With the machine stopped and raised, or
2. With the machine attached to the tractor and working.

To set the calibration with the machine stopped, do the following:

1. Support the machine securely, but in a way to allow the roller to turn freely.
2. Fill the hopper with the seed or fertilizer you intend to spread.
3. Make sure the seed cups are not plugged with leaves, grass or other obstacles and that the seed cup regulation levers are all adjusted to the same opening position.
4. Remove the seed tubes from the lower bar and attach bags to the ends to allow the material to be collected.
5. Move the calibration handle located in the rear of the hopper to a position between 1 and 6 (**see fig. 8**).
6. Turn the roller by hand in complete turns for a minimum of 20 turns. The greater the number of turns the more accurate the measurement will be.
7. Gather up and weigh all the material distributed in the bags. Divide this by the number of turns the roller made. This will give the amount of material dispersed per turn of the roller.
8. Each roller revolution, on the GRT-258 model, corresponds to a surface area of 13.88 square feet therefore 72 revolutions equal to 1,000 square feet and 3,137 roller revolutions equal to 1 acre. To obtain the amount of seed spread per acre, multiply the quantity obtained with each revolution by 3,137 (**see Table 2**).
9. If the results do not correspond to the desired amount which needs to be distributed, adjust the calibration handle accordingly.

**TABLE 2 - WORKING SURFACE**

GRT-250	GRT-258	GRT-266	GRT-282
1 revolution = 11.95 sq. ft	1 revolution = 13.88 sq. ft.	1 revolution = 17.62 sq. ft.	1 revolution = 19.59 sq. ft.
3646 revolutions = 1 acre	3137 revolutions = 1 acre	2773 revolutions = 1 acre	2224 revolutions = 1 acre
84 revolutions = 1000 sq. ft.	72 revolutions = 1000 sq. ft.	64 revolutions = 1000 sq. ft.	51 revolutions = 1000 sq. ft.

To calibrate the Green-Rite while it is working, do the following:

1. Measure out a predetermined distance on the ground (for example 200 linear feet), keeping in mind that the further the distance, the more precise the measurement.
2. Fill the hopper with the seed you intend to spread.
3. Make sure the seed cups are not plugged with leaves, grass or other obstacles and that the seed cup regulation levers are all adjusted to the same opening position.
4. Remove the seed tubes from the lower bar and attach bags to the ends to allow the material to be collected.
5. Move the calibration handle located in the rear of the hopper to a position between 1 and 6.
6. Drive the tractor forward pulling the machine along the predetermined distance. It is important for the roller to remain on the ground at all times and to roll continuously.
7. Collect all material distributed and weigh.

8. Using **Table 3** determine the amount of material distributed. **Example: If the distance traveled is 100 ft. and 0.1 lb. of material is collected, then 9.2 lb. per acre of material is being distributed.**
9. If the results do not correspond to the amount that needs to be distributed, adjust the calibration handle accordingly.

**TABLE 3 - AMOUNT OF MATERIAL DISTRIBUTED IN LB/ACRE**

Lb. collected all seed cups	Distance traveled in feet									
	100	200	300	400	500	600	700	800	900	1,000
0.1	9.2	4.6	3.1	2.3	1.9	1.5	1.2	1.1	0.9	0.8
0.5	45.7	22.8	15.3	11.4	9.2	7.6	6.5	5.7	5.0	4.5
1	91.6	45.8	30.4	22.8	18.3	15.3	13.0	11.4	10.1	9.2
1.5	137.4	68.7	45.8	34.4	27.5	22.8	19.6	17.1	15.2	13.7
2	183.1	91.5	61.1	45.8	36.6	30.5	26.2	22.9	20.4	18.3
2.5	229.0	114.4	76.3	57.3	45.8	38.2	32.7	28.6	25.5	22.9
3	274.7	137.3	91.5	68.7	55.0	45.8	39.3	34.3	30.5	27.5
3.5	320.5	160.3	106.8	80.1	64.1	53.4	45.8	40.0	35.6	32.1
4	366.3	183.2	122.1	91.6	73.3	61.1	52.4	45.8	40.7	36.6
4.5	412.0	206.1	137.3	103.0	82.4	68.7	58.9	51.5	45.8	41.2
5	457.9	228.9	152.6	114.5	91.5	76.3	65.4	57.2	50.9	45.8
5.5	503.7	251.8	167.9	125.9	100.7	83.9	71.9	62.9	55.9	50.4
6	549.4	274.7	183.2	137.4	109.9	91.5	78.5	68.7	61.1	55.0
6.5	595.2	297.6	198.4	148.8	119.0	99.2	85.0	74.4	66.2	59.6
7	641.0	320.5	213.7	160.2	128.2	106.8	91.6	80.1	71.2	64.1
7.5	686.8	343.4	228.9	171.7	137.4	114.4	98.1	85.9	76.3	68.7
8	732.6	366.3	244.2	183.1	146.5	122.1	104.7	91.6	81.4	73.2
8.5	778.3	389.2	259.4	194.6	155.7	129.7	111.2	97.3	86.5	77.8
9	824.1	412.1	274.7	206.0	164.8	137.4	117.7	103.1	91.6	82.4
9.5	869.9	435.0	290.0	217.4	174.0	145.0	124.2	108.8	96.6	87.0
10	915.7	457.9	305.2	228.9	183.2	152.6	130.8	114.5	101.7	91.5

### 3.10 - Seed Conveyor Kit

The seed conveyor kit for the hopper is designed to help feed all the seed to the seed distribution cups and reduce the amount of residue left over in the seed box. This is particularly useful with seed that is distributed in very low volumes since often times the seed box is not filled completely. When filling the seed box equipped with the seed conveyor kit, pay particular attention to filling the seed evenly across the whole hopper. Hoppers filled incorrectly could cause seed to be distributed unevenly.

The seed conveyors (**see #1, fig. 10**) are secured to the seed box using the fixing plates (**see #2, fig. 10**). No additional hardware is required as the fixing plates are fastened to the same holes on the hopper used to secure the seed cups (**see #3, fig. 10**).

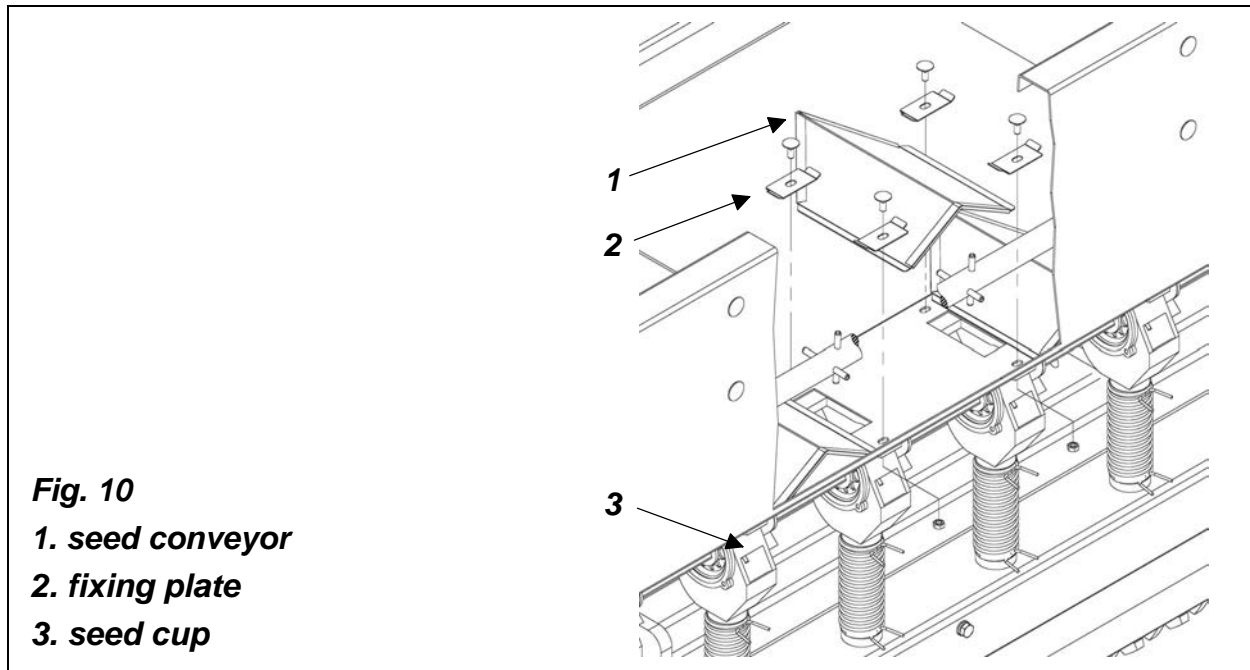

**Fig. 10**  
**1. seed conveyor**  
**2. fixing plate**  
**3. seed cup**

### 3.11 - Driveline



**DANGER:** Only use the original driveline supplied with this machine and always with the safety shielding. Carefully read and file away the driveline operator's manual supplied by the manufacturer. The following does not substitute the information found in the driveline manual.

**IMPORTANT:** Always check driveline length during initial setup and when connecting to a different tractor.

In the collapsed position the driveline should be approximately 2" from bottoming out to prevent possible damage to the tractor or implement. When the driveline is in the maximum extended position, the ideal minimum overlap of the two halves should be approximately 6" (**see fig. 11**).

If it is determined that the driveline is too long, follow these procedures to adjust the length.

1. Separate the two driveline halves. Connect one half to the tractor PTO and the other half to the implement.
2. Raise and lower the implement with the 3 point hitch to find the position where the driveline is shortest. Hold the half shafts side by side and mark the desired length on the outer female tube guard leaving a 2" gap between the end of the guard tube and bell guard.
3. Cut off both guard tubes the same amount as marked in step 2.

4. Shorten both drive tubes the same amount as the guard tubes.
5. De-burr and clean filings from drive tubes and apply grease to outside of inner telescoping tube.
6. Reassemble the driveline halves and connect to tractor and implement. Raise and lower machine again to be sure driveline does not bottom out in the shortest position and has a minimum overlap of 6" in the longest position.
7. Install both driveline safety chains. One should be hooked in a hole on the outer driveline yoke shield and to the tractor to restrict outer shield rotation. The second one should be hooked in a hole on the inner driveline yoke shield and to the implement to restrict inner shield rotation.

If determined that the driveline is too short for your tractor, contact your local dealer.

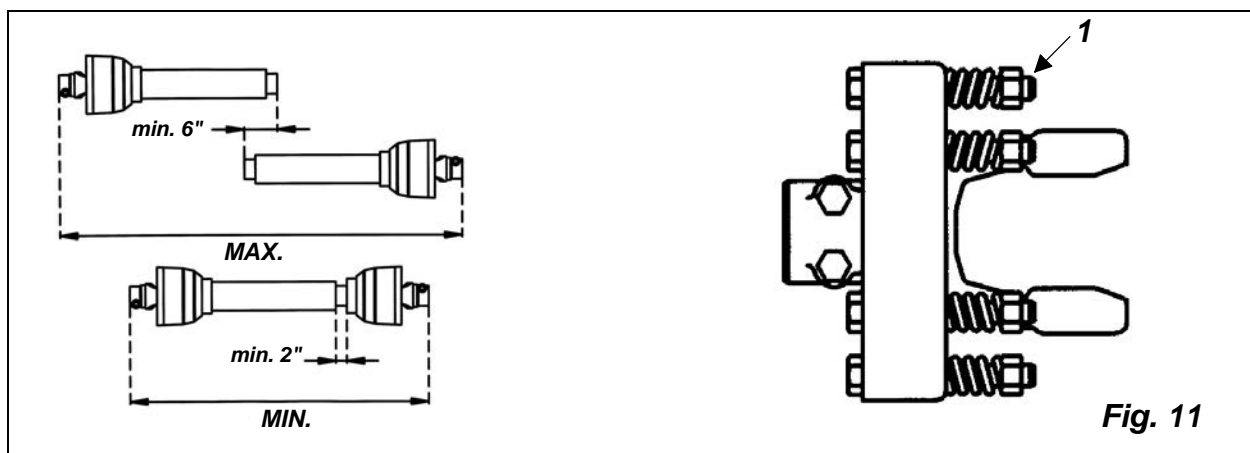

### 3.12 - Safety Slip Clutch

Your Green-Rite is supplied with a safety slip clutch. It is important to ensure that it is working properly. The slip clutch delivered with your machine is set at a specific torque for normal working conditions.

If the clutch slips frequently while the unit is working, it may be necessary to tighten the spring nuts (**see #1, fig. 11**) on the slip clutch. Tighten the spring nuts in  $\frac{1}{2}$  turn increments, then test run the unit for 600 to 800 ft. Repeat the operation if necessary. The discs on the clutch need to be replaced in the event that the clutch continues to slip even though the spring nuts have been tightened.

Follow the instructions in reverse, if while working under normal conditions the clutch does not slip at all.

### 3.13 - Pre-Operational Check

Check each of the following, carefully, prior to engaging machine:

1. The rotor support has been greased and the drive chain is lubricated.
2. The oil level in gearbox. Using a flashlight, check inside the gearbox to verify that it's approximately half full.

3. The driveline cross & bearings have been greased.
4. No wrappings or foreign objects are on the machine or driveline.
5. The blades are properly installed and the blade bolts and nuts properly torqued<sup>5</sup>.
6. All hardware is tight<sup>6</sup>.
7. The tractor to ensure correct direction of rotation of PTO and rpm speed.
8. All safety shields and guards are in their place and tightly attached.
9. No people or animals are in the work area.
10. Local utility companies have been contacted to make certain there are no bundled gas lines, electrical cables, etc., in the work area.
11. When working, make sure the Green-Rite has its full weight riding on the roller. The front of the machine should be held upward at a slight angle by the tractor arms.



**DANGER:** Always stay clear of rotating driveline and blades when the PTO is engaged.



**WARNING:** Disengage the PTO, apply the parking brake, shut off the engine and remove the key before attaching or removing the driveline, or performing any maintenance or adjustments on the machine.

### 3.14 - Attaching to the Tractor

Unit may be used on tractors equipped with a standard rear PTO with horsepower in the correct power range<sup>7</sup> and category 1 three point hitch.



**DANGER:** Never attempt to attach the Green-Rite to the tractor or make any adjustments to it without first turning the tractor off.



**CAUTION:** Check the tractor PTO rpm to ensure it is set at 540 and turns clockwise.



**CAUTION:** Be sure the tractor tire pressure is correct. It is important to strictly follow the safety guidelines and instructions laid out in the tractor manual.

---

<sup>5</sup> See Table 4, page 30.

<sup>6</sup> See Table 4, page 30.

<sup>7</sup> See Table 5, page 30.

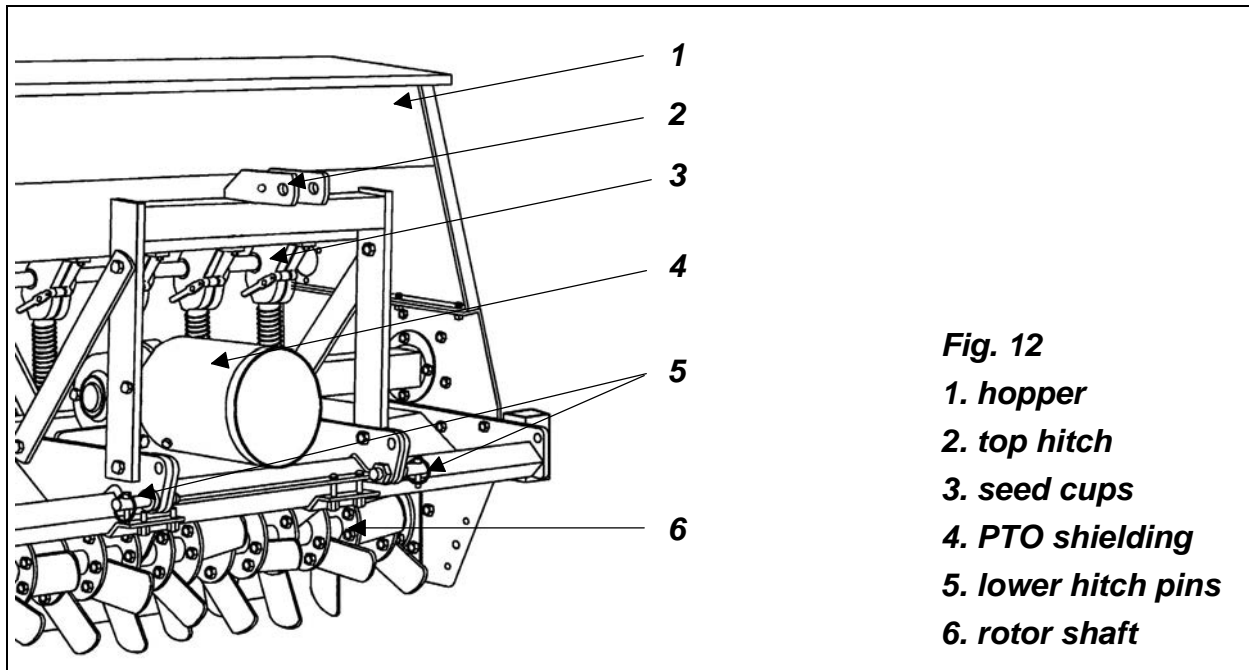

To attach the implement to the tractor do the following:

Back the tractor up to the Green-Rite in order to slip the tractor hitch arms over the hitch pins bolted to the frame. **Turn off the tractor engine.**

The lower hitch pins (**see fig. 12**) may be put in either of 2 positions (upper or lower) depending on the tractor. Optional hitch blocks are available for use on tractors with non standard three point hitches. Secure the two arms with the lynch pins. Tighten the tractor arms side movement with either the sway chains or blocks to limit side swing to 2"-3". Connect the top link, locking it in place with the top hitch pin. Adjust it so the Green-Rite is as near parallel to the ground as possible. A 1° to 2° rearward tilt is acceptable (**see fig. 13**).

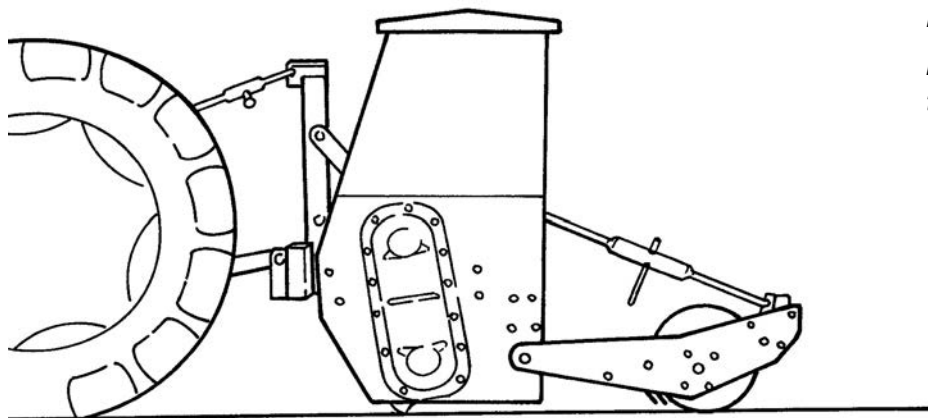

Install the end of the driveline with the safety slip clutch to the machine and the opposite end to the tractor PTO. Be sure each end is connected securely with either the locking



pin or bolt and nut. Connect the driveline chains to the tractor and to the machine to prevent the protective shielding from rotating during operation. If it was necessary to remove the PTO protection to do any of the above operations, do not forget to replace it.

**IMPORTANT:** See Section 3.10 - Driveline, to ensure the driveline is the proper length.

After use, if the machine is not supplied with front gauge wheels or a front roller, the machine should be lowered and allowed to rest on the stand which is supplied with the machine (see fig. 14).

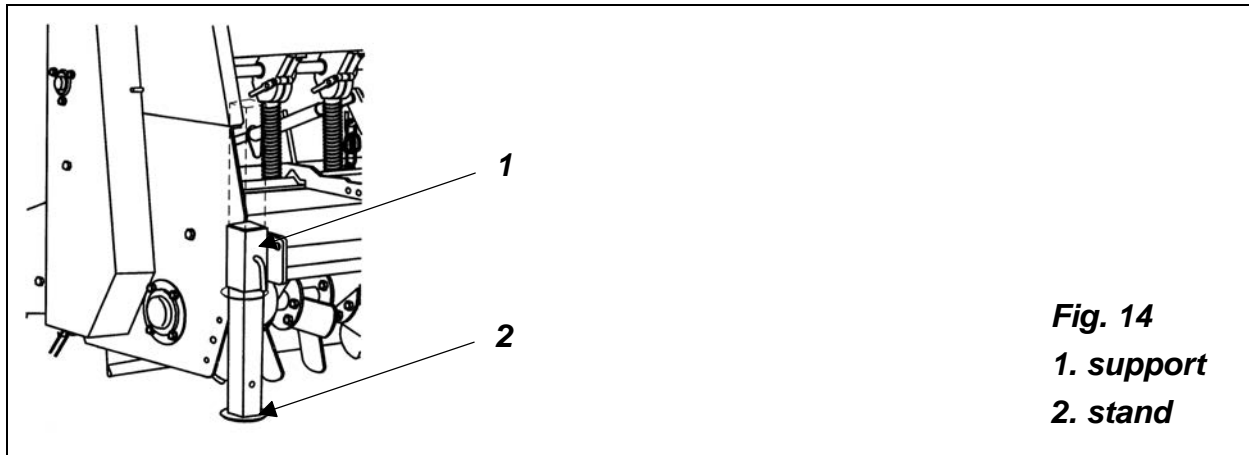

**Fig. 14**  
**1. support**  
**2. stand**

### 3.15 - Start Up



**DANGER:** Never allow anyone around the Green-Rite when it is in operation. Never engage the tractor PTO before the tines are about to touch the ground.



**DANGER:** Operate the implement only at the speed and direction of rotation indicated on the machine. Serious damage can result if this is not followed.



**CAUTION:** Before starting work, clear the area of any obstacles or foreign objects.

The Green-Rite is set up to be used on tractors with a PTO of 540 rpm. With the engine in neutral and tractor rpm low, engage the PTO and very slowly bring the tractor rpm up

to  $\frac{3}{4}$  its normal working speed. Lower the machine to the ground and increase the rpm until a PTO speed of 540 is reached. Never operate over 540 rpm.

**When using the maximum rated horsepower tractors, it is important to “feather in” the PTO. Sudden jolts of high power can cause damage to the driveline or gearbox<sup>8</sup>.**

Start out with the tractor in the lowest gear, increase gears slowly if necessary. **Avoid working in reverse.**

Before beginning work always remember that the operator is responsible for:

1. Safe and correct operation of the tractor and Green-Rite.
2. Learning and following precise, safe operating procedures for both the tractor and the Green-Rite.
3. Ensuring all maintenance and lubrication has been performed on the Green-Rite.
4. Having read and understood all safety aspects for the Green-Rite in the operator's manual.
5. Having read and understood all safety decals on the Green-Rite.
6. Checking the condition of the blades. Worn or damaged blades should be changed before starting.
7. Checking to ensure that the cutting edge is the leading edge of the blade.
8. Checking that there are no wires, weeds, grass or other objects wrapped around the rotor.
9. Checking to see if front weights need to be added to the tractor in order to maintain balance.
10. Checking the tractor tires for the proper pressure in accordance to the tractor operator's manual.
11. Checking that all shielding is on the machine and securely in place.
12. Making sure the proper attire is worn. Avoiding loose fitting clothing which can become entangled. Wearing sturdy, tough-soled work shoes and protective equipment for eyes, hands, ears and head. Never operate tractor or implement barefoot, or wearing sandals or sneakers.
13. Checking area for stones, branches and other debris that might be thrown.
14. Ensuring proper lighting is available, sunlight or good artificial lighting.



**DANGER: Never use the machine without first assuring all protective devices are properly installed. Never forget that due to their high blade tip speed, blades can be thrown great distances and cause injury or death to bystanders.**



**CAUTION: For emergency reasons, learn how to stop the tractor and implement quickly. On the Green-Rite, always disengage the PTO, lock parking brake, stop**

---

<sup>8</sup> See Table 5, page 30.

engine and allow the blades to come to a complete stop before dismounting the tractor.

### 3.16 - Test Run

After the first 200-300 feet it is important to stop, raise the machine and disengage the PTO just as the blades are coming out of the ground. Lower the machine, turn off the tractor engine and remove the key.

At this point make sure the Green-Rite is performing correctly. Check for loose bolts or nuts, paying particular attention to the blade bolts.

### 3.17 - Working Depth

When using the **aerating rotor** which comes standard with the machine, normally a depth of approximately  $\frac{3}{4}$ " is all that is desired. This is enough to loosen the soil without tearing up existing grass. It is very important to check the depth prior to the corrugated roller going over where the blades have cut into the ground.

With the optional **tilling rotor** the depth of cut is determined largely by the condition of the ground. When working hard or previously unworked ground, set depth at no more than 2"-3". Greater depth may require a second pass. The maximum tilling depth is 7" or 9" depending on the Green-Rite model.

**NOTE: Excessive vibration or jumping of the machine is an indication that the machine is working too deep for conditions, such as in hard, parched or compacted soil and should be adjusted accordingly.**

### 3.18 - Working Speed

Ground speed is determined by the soil condition, depth of cut, and tractor power. Simple experimentation will soon determine the best speed for the desired results, usually 1 to 2 mph.

When using the **aerating rotor** the blades need to make a continuous slice, if there is some skipping you need to slow down the ground speed.

A slow ground speed with the **tilling rotor** will result in a finer soil, as a faster ground speed will render the opposite. The rear shield, besides being a safety device, will help in producing a finer worked soil. Test results show that a raised shield will leave a coarser finished surface.

### 3.19 - Headland Procedure

When the headland is reached, it is important that the following be observed:

1. Raise the machine from the ground and as soon as the blades leave the ground, disengage the tractor PTO.
2. Turn the tractor facing the new desired direction of travel.

3. Begin working again.

**NOTE: Best practice dictates that the machine be lifted no more than just enough to clear the ground. Running the machine at an angle above 15° could damage the PTO.**

### 3.20 - Working Limitations

When using the tilling rotor, if the blades will not penetrate the ground easily or the machine jumps and vibrates excessively, conditions may be too dry, tough or compacted. (Also make sure that the blades are properly installed<sup>9</sup> with the proper scroll and the bolts properly torqued<sup>10</sup>).

Under these extreme conditions it may be wise not to use the tiller as a primary tillage tool. Run over the ground with a disc or plow prior to tilling.

### 3.21 - Uneven Terrain



**DANGER: Be careful when operating tractor and machine over uneven ground to avoid rollover.**

The following precautions should always be observed when working on uneven terrain:

1. In extremely uneven terrain rear wheel weights, front tractor weights, and/or tire ballast should be used to improve stability.
2. Observe the type of terrain and develop a safe working pattern.
3. Whenever traction or stability is doubtful, first test drive over the terrain with the PTO disengaged.
4. Operate the implement up and down steep slopes, not across slopes, to prevent the tractor from tipping. Avoid sudden stops and starts, and slow down before changing directions on a slope.
5. Pass diagonally through sharp dips and avoid sharp drops to prevent hanging up the tractor and implement.
6. Slow down on sharp turns and slopes to prevent tipping or loss of control.
7. Watch for holes, roots or other hidden objects. Do not use near the edge of a gully, ditch or stream bank.

---

<sup>9</sup> See Section 4.04 - Blade Maintenance.

<sup>10</sup> See Table 4, page 30.

## 3.22 - Transporting



**CAUTION:** All operations of transport are to be done without the Green-Rite working and respecting all local traffic rules and regulations.





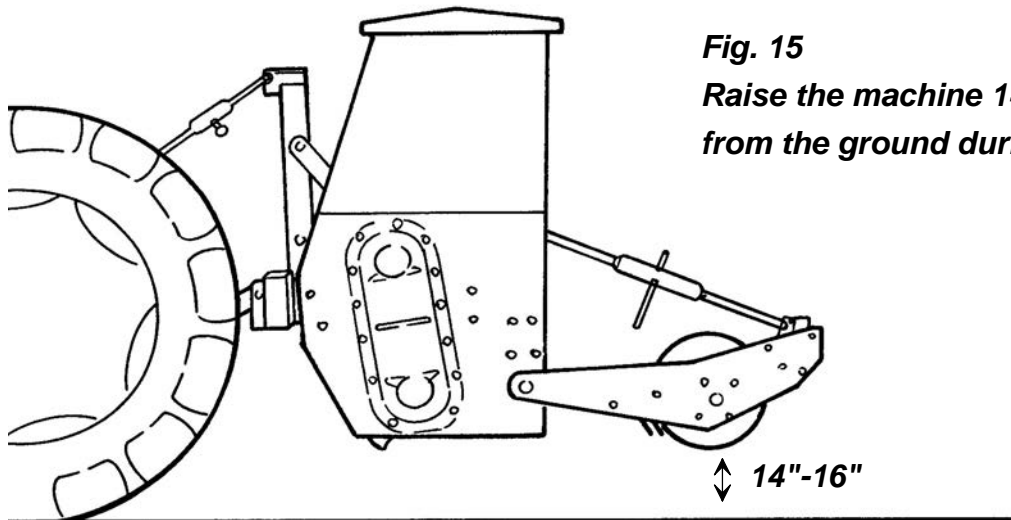

During transport or when the machine is lifted from the ground, it is advisable to adjust the tractor lift arms in order to be able to raise the machine 14" to 16" from the ground (see fig. 15).

Before transporting:

1. Always select a safe ground speed that is appropriate for the terrain.
2. Beware of traffic on public roads. Install a SMV (Slow Moving Vehicle) sign when traveling on roads or streets. Comply with all federal, state and local laws.
3. Reduce ground speed when turning and take care that the implement does not strike obstacles such as trees, fences or buildings.
4. Always disengage PTO before raising the implement to transport position.
5. When raising the implement be sure the PTO driveline does not hit either the implement or the tractor.
6. During transport the implement should not be lifted over 14" to 16" from the ground.



**TABLE 4 - BOLT AND NUT TORQUE SPECIFICATIONS**

Metric (ISO) treaded bolts head marking							Inch (SAE) treaded bolts head marking								
	Class 5.8		Class 8.8		Class 10.9			Grade 2		Grade 5		Grade 8			
Bolt size mm	Thread mm	N.m	ft-lb	N.m	ft-lb	N.m	ft-lb	Bolt size inch	Thread inch tpi	N.m	ft-lb	N.m	ft-lb	N.m	ft-lb
M5	0.8	4	3	6	4	9	7	1/4"	20	7	5	11	8	16	12
M6	1	6	4	10	7	15	11	1/4"	28	8	6	13	10	19	14
M8	1.25	16	12	25	18	36	27	5/16"	18	15	11	24	17	33	25
M8	1	17	13	26	19	38	28	5/16"	24	17	13	26	19	37	27
M10	1.5	31	23	48	35	71	52	3/8"	16	27	20	42	31	59	44
M10	1.25	33	24	51	38	75	55	3/8"	24	31	23	47	35	67	49
M10	1	35	26	53	39	78	58	7/16"	14	43	32	67	49	95	70
M12	1.75	54	40	84	62	123	91	7/16"	20	48	36	75	55	106	78
M12	1.5	56	41	87	64	128	94	1/2"	13	66	48	102	75	144	106
M12	1.25	59	44	90	66	133	98	1/2"	20	75	55	115	85	163	120
M14	2	84	62	133	98	195	144	9/16"	12	95	70	147	109	208	154
M14	1.5	94	69	142	105	209	154	9/16"	18	106	79	164	121	232	171
M16	2	131	97	206	152	302	223	5/8"	11	132	97	203	150	287	212
M16	1.5	141	104	218	161	320	236	5/8"	18	149	110	230	170	325	240
M18	2.5	181	133	295	218	421	310	3/4"	10	233	172	361	266	509	376
M18	2	196	145	311	229	443	327	3/4"	16	261	192	403	297	569	420
M18	1.5	203	150	327	241	465	343	7/8"	9	226	167	582	430	822	606
M20	2.5	256	189	415	306	592	437	7/8"	14	249	184	642	473	906	668
M20	1.5	288	212	454	335	646	476	1"	8	339	250	873	644	1,232	909
M22	2.5	344	254	567	418	807	595	1"	12	371	273	955	704	1,348	995
M22	1.5	381	281	613	452	873	644	1-1/8"	7	480	354	1,077	794	1,746	1,288
M24	3	444	327	714	526	1,017	750	1-1/8"	12	539	397	1,208	891	1,958	1,445
M24	2	488	360	769	567	1,095	808	1-1/4"	7	677	500	1,519	1,120	2,463	1,817
M27	3	656	484	1,050	774	1,496	1,103	1-1/4"	12	750	553	1,682	1,241	2,728	2,012
M27	2	719	530	1,119	825	1,594	1,176	1-3/8"	6	888	655	1,992	1,469	3,230	2,382
M30	3.5	906	668	1,420	1,047	2,033	1,499	1-3/8"	12	1,011	746	2,268	1,673	3,677	2,712
M30	2	1,000	738	1,600	1,180	2,250	1,659	1-1/2"	6	1,179	869	2,643	1,949	4,286	3,161
M36	4	1,534	1,131	2,482	1,830	3,535	2,607	1-1/2"	12	1,326	978	2,974	2,194	4,823	3,557

When using lock washers with nuts, increase torque values by 5%.

**TABLE 5 - GREEN-RITE - TECHNICAL FEATURES**

Green-Rite for tractors with PTO 540 rpm, cat. 1 three point hitch.											
Model	HP	Working width	Overall width	Weight lb.	Hopper capacity cu. ft.	# Flanges	# Blades	Rotor rpm	Chain sprockets	Working depth	Driveline 1 3/8" slip clutch
<b>Machine with straight blade aerating rotor.</b>											
GRT-250	25-45	50"	57"	910	4.6	15	43	231	11-14	7.2"	ASAE 3 <sup>rd</sup> cat.
GRT-258	30-45	58"	66"	998	5.3	18	52	231	11-14	7.2"	ASAE 3 <sup>rd</sup> cat.
GRT-266	32-45	66"	74"	1,170	6	21	61	231	11-14	7.2"	ASAE 3 <sup>rd</sup> cat.
GRT-282	40-70	82"	89"	1,500	7.6	26	104	221	12-14	8.6"	ASAE 6 <sup>th</sup> cat.
<b>Machine with tilling rotor.</b>											
GRT-250	25-45	50"	57"	902	4.6	6	24	231	11-14	7.2"	ASAE 3 <sup>rd</sup> cat.
GRT-258	30-45	58"	66"	992	5.3	7	28	231	11-14	7.2"	ASAE 3 <sup>rd</sup> cat.
GRT-266	32-45	66"	74"	1,160	6	8	32	231	11-14	7.2"	ASAE 3 <sup>rd</sup> cat.
GRT-282	40-70	82"	89"	1,490	7.6	10	40	221	12-14	8.6"	ASAE 6 <sup>th</sup> cat.

## 4 - MAINTENANCE



**DANGER: Stop engine, lock parking brake and remove key before performing any service or maintenance.**

**Never rely on the tractor lift system. Install blocks or stands under the implement deck to prevent it from falling.**

**Always use personal protection devices, such as glasses or gloves when performing maintenance.**

**Keep fingers out of slots to prevent injury.**

### 4.01 - Maintenance Safety



1. Good maintenance is your responsibility.
2. Keep service area clean and dry. Be sure electrical outlets and tools are properly grounded. Use adequate light for the job at hand.
3. Make sure there is plenty of ventilation. Never operate the engine of the towing vehicle in a closed building. The exhaust fumes may cause asphyxiation.
4. Make no repair or adjustments with the tractor engine running. Before working on the machine, disengage the PTO, shut off the engine, set the brakes, and remove the ignition key.
5. Be certain all moving parts on attachment have come to a complete stop before attempting to perform maintenance.
6. Never work under equipment unless it is blocked securely.
7. Never trust the tractor hydraulics alone to support the machine. Before repairing or adjusting, the machine should be lowered and allowed to rest on the supplied stand.
8. Always use personal protection devices such as eye, hand and hearing protectors, when performing any service or maintenance.
9. Frequently check blades. They should be sharp, free of nicks and cracks and securely fastened.
10. Periodically tighten all bolts, nuts and screws and check that all cotter pins are properly installed to ensure unit is in a safe condition.
11. When completing a maintenance or service function, make sure all safety shields and devices are installed before placing unit in service.
12. Do not attempt to mount a tire unless you have the proper equipment and experience to do the job.
13. Inflating or servicing tires can be dangerous. Whenever possible, trained personnel should be called to service and/or mount tires.
14. After servicing, be sure all tools, parts and service equipment are removed.

15. Never replace hex bolts with less than grade five bolts unless otherwise specified, i.e. shear bolts<sup>11</sup>.
16. When the machine is not hooked to the tractor, the driveline must be stored in a safe place.
17. Where replacement parts are necessary for periodic maintenance and servicing, genuine replacement parts must be used to restore your equipment to original specifications. The company will not claim responsibility for use of unapproved parts and/or accessories and other damages as a result of their use.
18. Unauthorized modifications to the machine may impair the function and/or safety of the machine and reduce its life. If equipment has been altered in any way from original design, the manufacturer does not accept any liability for injury or warranty.

## 4.02 - Service

The following illustrations show lubrication points. The frequency of lubrication given is based on normal operating conditions. Severe or unusual conditions may require more frequent lubrication.

Use a good quality SAE multipurpose type grease for all locations shown. Be sure to clean fittings thoroughly before using grease gun. Immediately replace broken or missing fittings.

Use 90W gear oil in gearbox.

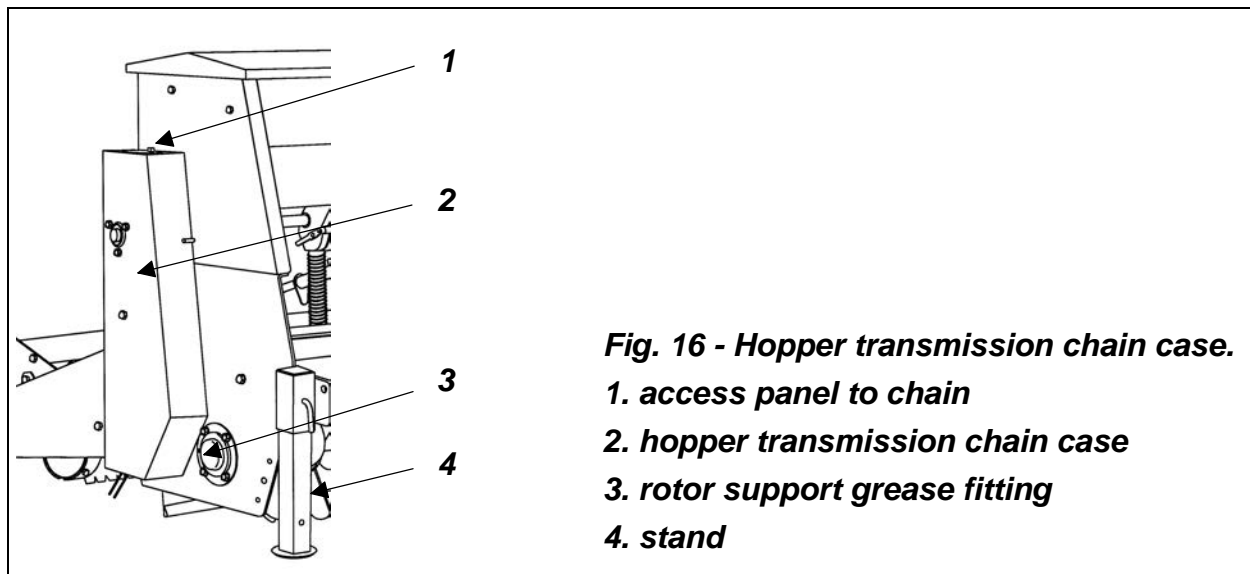

**Fig. 16 - Hopper transmission chain case.**

**1. access panel to chain**

**2. hopper transmission chain case**

**3. rotor support grease fitting**

**4. stand**

### Seed hopper clean out:

The seed cups on the hopper are designed for easy clean out. To completely clean out the seed hopper, move the main seed calibration handle on the hopper in the fully open position (**see fig. 8**), then move the seed cup regulation lever (**see fig. 9**) into the clean out position. Use a soft brush to guide any remaining seed in the hopper through the seed cups.

<sup>11</sup> Refer to Table 4 - Torque Specifications, page 30.



Whenever the hopper is used for fertilizer spreading it is extremely important to carefully clean out the hopper and wash the machine with hot water. Do not forget that fertilizer is highly corrosive and should be not left in the hopper any longer than necessary.

**Hourly or whenever an obstacle is hit:**

1. Check machine condition, particularly the blades.
2. Replace any damaged or worn blades.
3. Remove any wrapping (stalks, weeds, trash, etc.) from rotor, especially from around bearing supports on the rotor ends.

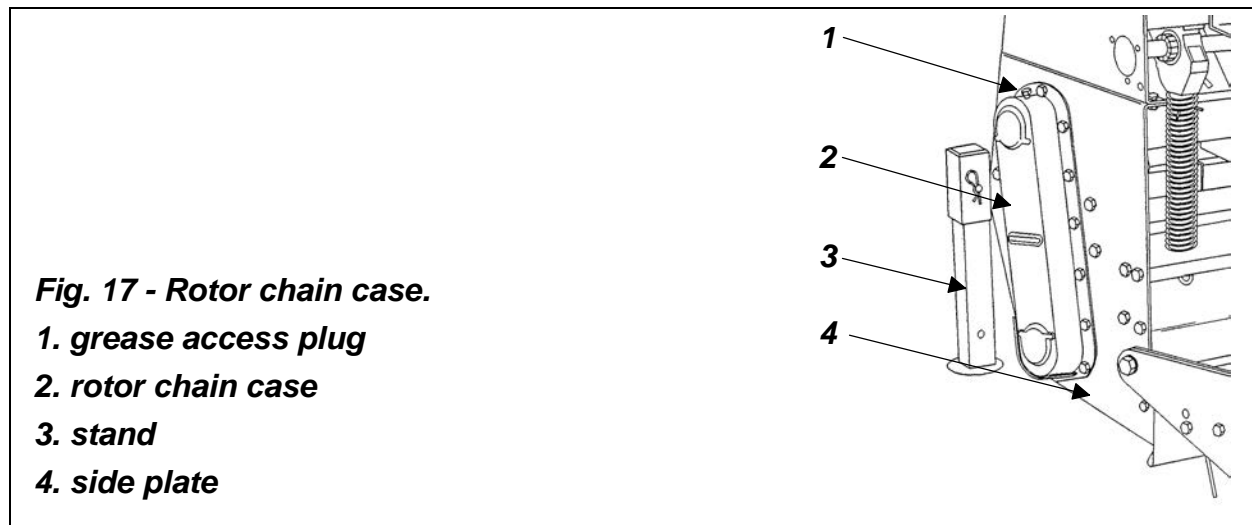

**Every 8 hours:**

1. **Grease the rotor support (see fig. 16) and the roller support (see fig. 18), the driveline cross and bearings and the telescopic tubes.** Apply two or three shots of grease to the driveline cross and bearings and the telescoping shafts. Apply the same amount to the rotor and roller bearings.
2. **Gearbox oil level;** check oil level by removing the breather plug. Using a flashlight, check inside the gearbox to verify that it's approximately half full. When filled correctly the oil level should be halfway on the input shaft. When fully drained GRT-250, 258 and 266 gearbox requires approximately 20 fl. oz. (0.6 qt.) of oil while GRT-282 gearbox requires approximately 61 fl. oz. (1.9 qt.) of oil. If needed add SAE 90W gear oil.

**Note:** Never overfill gearbox. Oil will expand when hot. Overfilling will likely cause excess oil to blow out of breather cap.

**Every 25 hours:**

**Check hardware tightness;** vibration can loosen bolts<sup>12</sup>. Check tightness of the hardware periodically<sup>13</sup>.

<sup>12</sup> See Table 4, page 30.

<sup>13</sup> See Table 4, page 30.

**Every 50 hours:**

**Check the blades** for excessive wear or damage. Be sure the rotor turns freely. Inspect all the drive chains and make sure they are well lubricated (see fig. 16 and 17).

**After the first 200 hours:**

**Remove the rotor chain case cover** (see fig. 17) (being sure not to damage the gasket), clean the chain sprockets with kerosene, replace the sprockets and reassemble using fresh GP grease (approximately) 2.2 lb.

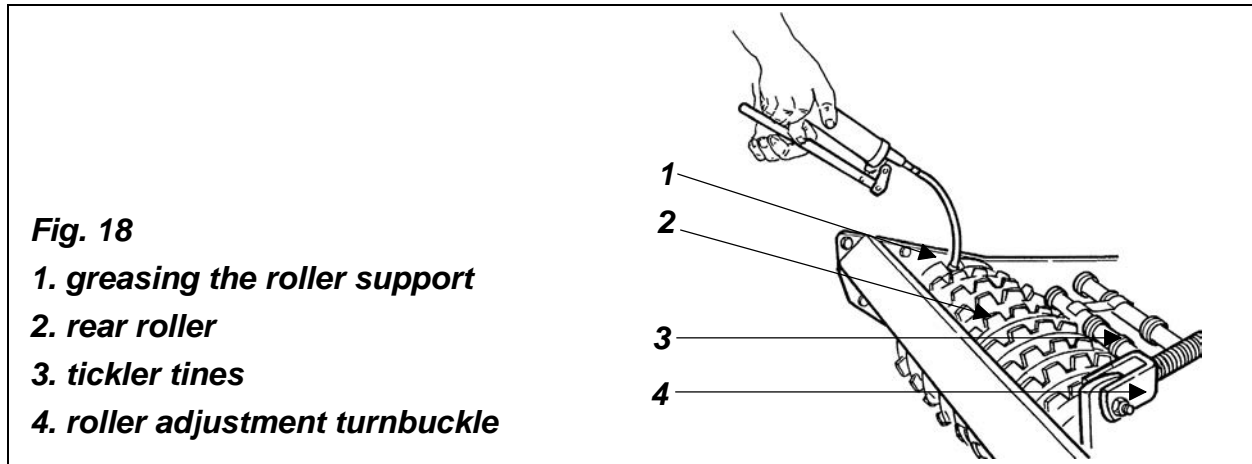

### 4.03 - Changing Rotors

The Green-Rite can use two different types of blades: A straight aerating blade and a standard tilling blade. Each of the two types requires a different rotor.

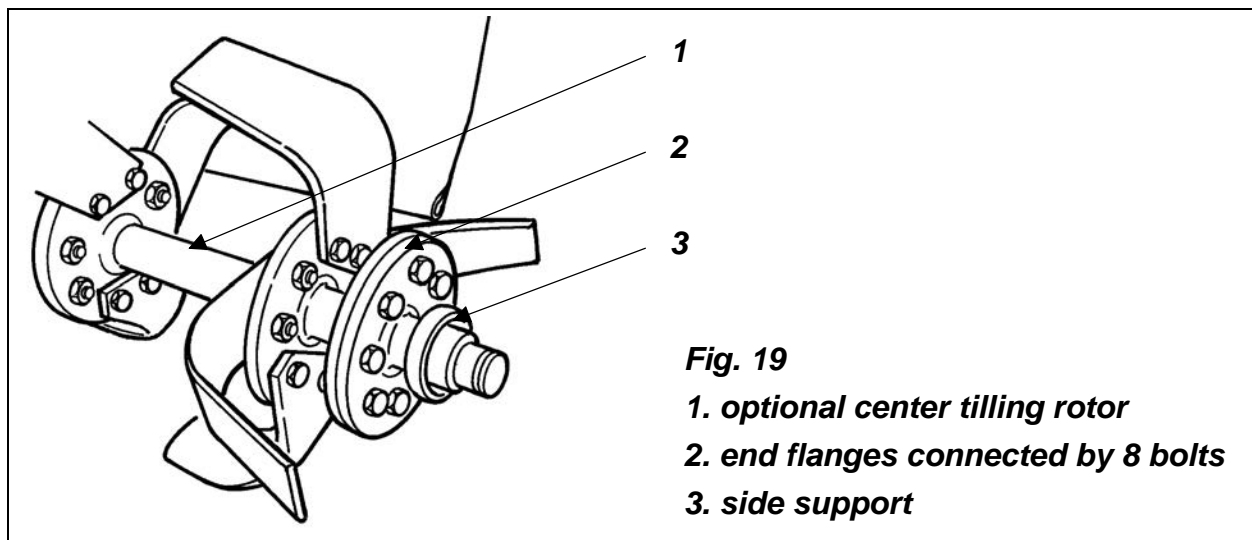

It is always recommended to purchase the machine with both rotors in order to get the most use out of the Green-Rite. Changing the rotor is a very simple operation. Both

types consist of two side supports and a center flanged rotor. The center flanged rotor is either an aerating rotor or a tilling rotor. The two side supports (one left and one right) are the same for whichever center rotor is being used. The center rotor is bolted to the two side supports by 16 bolts (8 per side) (**see fig. 19**).

To change from one rotor to the other, unbolt these 16 bolts, remove the center rotor and bolt the other rotor in place. An operation which is performed in just a few minutes but gives great flexibility to the machine.

## 4.04 - Blade Maintenance



**WARNING:** Avoid possible injury. Wear proper eye and hand protection when servicing machine blades.

It is important to change blades after **they have worn down 1-1¼”** from their original length. When replacing blades, it is best to replace them one at a time to maintain the original scroll pattern. If, however, it becomes necessary to remove them all, **it is essential to maintain the scroll pattern of the blades (see fig. 20)**. To do this, remove one blade and immediately replace it with a new one. Be sure the bolt head (**see #3, fig. 21**) is touching the blade **#4**, while the washer **#5** and nut **#6** contact the flange. Sometimes a locknut is used instead of a lockwasher and nut. Proceed until all blades needed to be changed are changed.

After installing the new blades, tighten the nuts to their proper torque specifications.

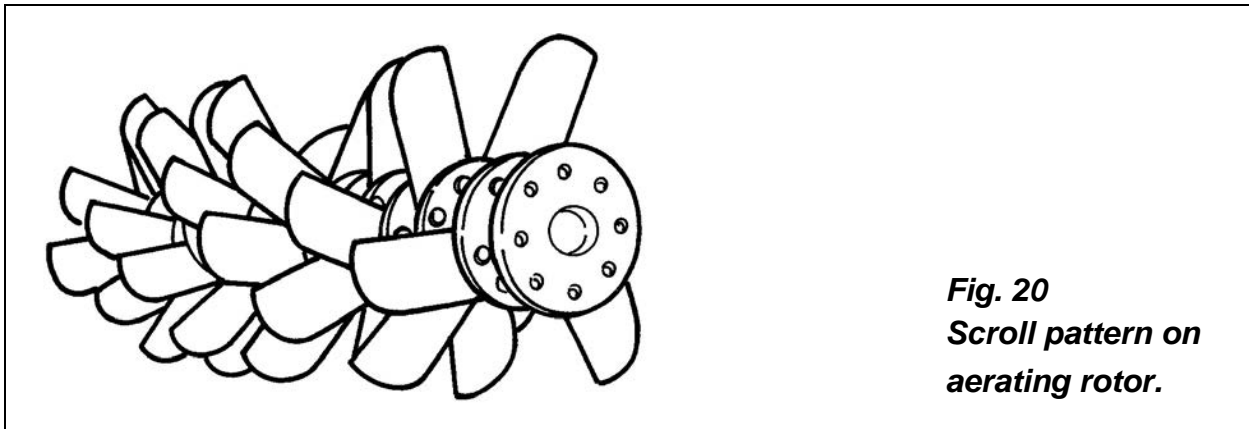

**Fig. 20**  
**Scroll pattern on**  
**aerating rotor.**

To determine if a blade is right or left, do the following:

1. Hold the blade in the palm of the hand with the bend pointing upward and away from you.
2. If the cutting edge points towards the right then the blade is right-handed.
3. The cutting edge pointing to the left indicates a left-handed blade.

**NOTE:** On the aerating rotor, all blades are the same. It is not necessary to determine a left or right.



**DANGER:** Proper torque must be used when tightening the blade retaining bolt. If these safety precautions are not followed, the blade could come off during operation and be thrown hundreds of feet from the machine.

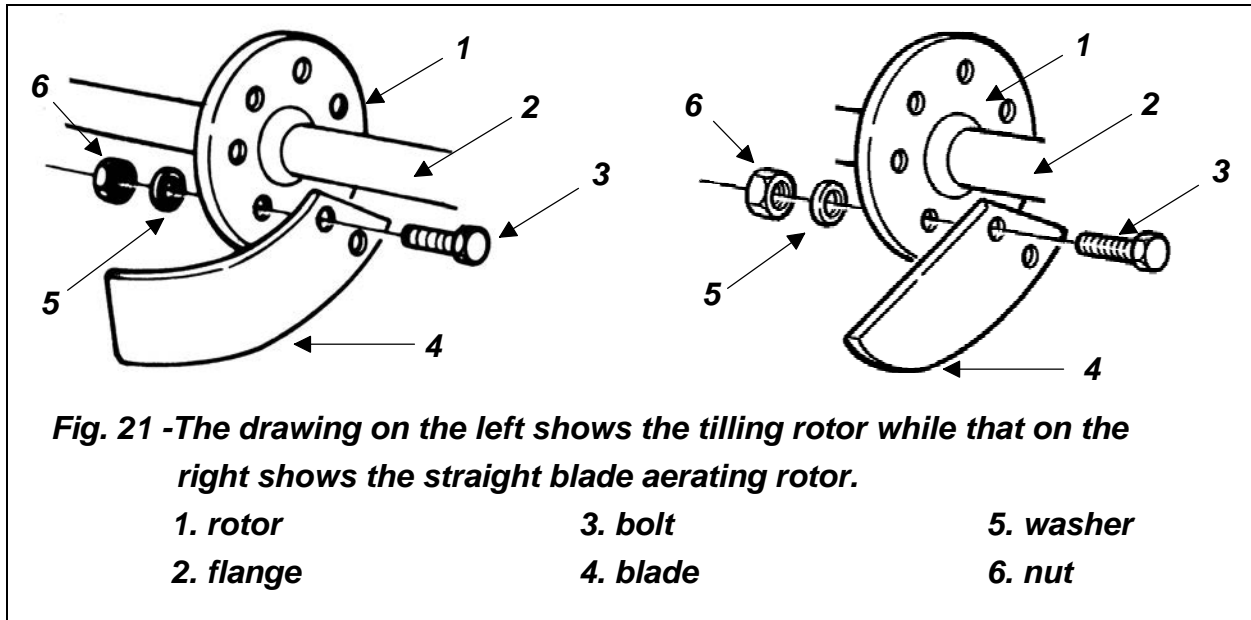

## 5 - REPAIR PROCEDURES



**CAUTION:** All repair procedures must be done by authorized dealerships. It is not recommended that untrained individuals perform any repair work. The following operations are detailed for qualified personnel only.

### 5.01 - Gearbox

To remove the gearbox from the side shift frame proceed as follows:

1. Remove the front and the rear bolts holding the gearbox to the side shift frame.
2. Slide the side shift frame over until the gearbox is off the hexagonal shaft.
3. Whenever the bearings are removed from the gearbox, all **oil seals should be replaced** to assure no leaks when the box is reassembled.
4. To avoid damage to components, bearings should always be removed with bearing pullers and pressed in when being replaced.
5. When reassembling the gearbox, ensure that there is a precise match between ring and pinion gears.
6. Fill gearbox of models GRT-250, GRT-258, GRT-266 with approximately 20 fl. oz. (0.6 qt.) of oil and model GRT-282 with approximately 61 fl. oz. (1.9 qt.) of oil. Use SAE 90W gear oil. Oil level in gearbox should be half full.

### 5.02 - Rotor Chain Case

To remove the chain do the following:

1. Unbolt the rotor chain case cover.
2. Remove the chain case cover taking care not to damage the gasket.
3. Release the automatic chain tensioner spring.
4. Remove the two snap rings holding the chain sprockets.
5. Slip off both chain sprockets at the same time.

To replace the chain follow the procedure in reverse order, ensuring the gasket is not damaged. If damaged it must be changed.

### 5.03 - Removing the Rotor

To remove the rotor proceed as follows (see fig. 19):

1. Unbolt the 16 bolts holding the center rotor to the right and left side supports.
2. Remove the rotor.

When replacing the rotor, do not force and take care not to damage the bearings and seals in the supports.

## 5.04 - Hopper Transmission Chain Case

To remove the hopper transmission chains do the following:

1. Remove the bolts that secure the upper and lower chain case cover to the frame.
2. Loosen the two set screws that hold the flange bearing to the pinion auger shaft.
3. Remove the chain case covers.
4. Disconnect the turnbuckle that runs from the frame to the rear roller of the unit so that the rear roller can pivot freely up and down.
5. Using a hoist, raise the rear roller to create slack on the lower chain ASA 50x92 (**see #8, fig. 22**).
6. When the lower chain has sufficient slack, remove the lower chain from the unit.
7. Release the chain tensioner spring (**see #4, fig. 22**) from the upper chain ASA 50x82 (**see #1, fig. 22**).
8. Remove the upper chain from the unit.

To replace the hopper transmission chains do the following:

1. Loosely place upper chain ASA 50x82 over the small inner sprocket of the bottom sprocket assembly (**see #5, fig. 22**) then run the top of the chain over an around the top sprocket Z22 (**see #2, fig. 22**) and to the outside of the sprocket Z15 (**see #3, fig. 22**).
2. Using a hoist, raise the rear roller until you have sufficient room to install the lower chain.
3. Loosely place the lower chain ASA 50x92 over the large outer sprocket of the bottom sprocket assembly (**see #5, fig. 22**) then run the lower chain over the front sprocket and under the rear sprocket on the chain adjuster support (**see #6, fig. 22**) then run the chain around the sprocket Z13 that is connected to the rear roller (**see #7, fig. 22**).
4. Stand directly behind the chain transmission and verify that both chains are properly aligned and run straight. If you notice that one or both chains are not properly aligned you will have to readjust one or more of the sprockets that is causing the chain misalignment.
5. Engage the chain tensioner spring for the upper chain by hooking the spring into the hole (**see #9, fig. 22**).
6. Reattach the turnbuckle to the rear roller of the unit.
7. Replace the lower chain case cover and secure it with the two bolts.
8. Replace the upper chain case cover making sure to insert the pinion auger shaft through the flange bearing. Secure the chain case cover with the bolt.
9. Tighten the two set screws that hold the flange bearing to the pinion auger shaft.

**Fig. 22 - Hopper transmission chains assembly.**

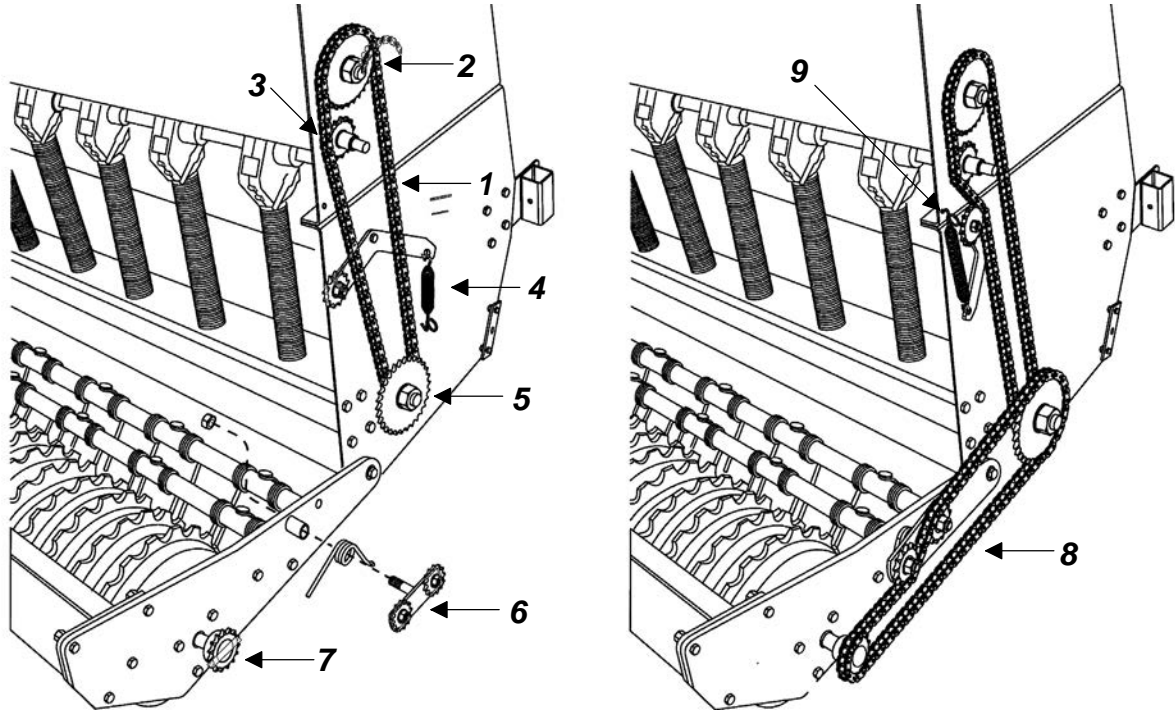

**A. Loosely place upper chain over the small inner sprocket of the bottom sprocket assembly then run top of the chain over and around the top sprocket.**

**B. Using a hoist raise the rear roller and loosely place the lower chain over the large outer sprocket of the bottom sprocket assembly then run the chain over the front sprocket and under the rear sprocket on the chain adjuster support. Finally run the chain around the small rear sprocket.**

### 5.05 - Suggested Spare Parts

It is suggested that the following spare parts be kept on hand at all times to prevent a minor problem from delaying work:

Description	Quantity
Aerating blades	6
Tilling blade, right	5
Tilling blade, left	5
Blade bolts	10
Nuts	10
Chains	1 set

## 5.06 - Storage

After seasonal use it is important to perform the following for prolonged storage:

1. If the machine is not supplied with the optional gauge wheels or front roller, lower the stand and pin in its lowest position (**see fig. 14**).
2. Wash the Green-Rite carefully, especially inside the hopper.
3. Inspect the Green-Rite and replace worn or damaged parts.
4. Tighten all hardware.
5. Grease all areas indicated under Maintenance<sup>14</sup>.
6. Touch up scratches by sanding the area and applying a light coat of primer and paint to prevent rust from forming.
7. Cover the Green-Rite from the elements in order to have it in perfect condition for the start of the next season.
8. Make sure all parked machines are on a hard, level surface, and engage all safety devices.
9. Do not permit children to play on or around the stored unit.

<b>Touch up paint available:</b>	
<b>Part #</b>	<b>Description</b>
7300007	Primer, gray - aerosol spray can
7300008	Paint, Befco orange - aerosol spray can
7300010	Paint, Befco black - aerosol spray can



**WARNING:** Be sure to store the implement on a hard level surface and away from people especially children.

The machine demolition operations should be carried out in compliance with all federal, state and local environment protection laws.

---

<sup>14</sup> See Chapter 4 - Maintenance.



## 6 - TROUBLESHOOTING



**WARNING:** Be sure tractor engine is off, parking brake is locked, and key is removed before making any adjustments.

PROBLEM	POSSIBLE CAUSE	SOLUTION
Machine makes intermitting clicking noise.	Loose blade bolts. Gearbox gears or chain damaged.	Tighten blade bolts. Replace damaged gears or chain.
PTO vibrates.	Worn cross & bearings. Driveline at too great of an angle. Wrappings around rotor shaft.	Replace worn cross & bearings. Machine working too high and the driveline at too much of an angle. Check for wrappings on rotor shaft.
Gearbox noise is noticeable and constant.	Oil level low. Worn Gears.	This can be normal on a new machine until it has been run in. Check oil level. Replace worn gears.
Blades stop turning but PTO, gearbox and hexshaft are.	Broken drive chain.	Remove chain case and check for broken connector link.
PTO turning but not blades.	Slip clutch slipping.	Adjust slip clutch or replace discs.
Machine skips and leaves crop residue.	Worn blades. Slip clutch slipping. Ground speed too fast.	Check for badly worn blades. If worn down to tip, overlap will be lost and cutting will deteriorate. Replace worn blades. If slip clutch is used, check performance. Reduce ground speed.
Machine smells hot or begins to smoke.	Wrappings around rotor. Gearbox oil low. Slip clutch slipping.	Can be caused by friction from trash heavily wrapped around bearing protection covers. Remove trash immediately, as damage to bearing could result. Check oil level in gearbox and lubricant on chain. Check slip clutch if fitted. Adjust if needed.
Oil leak from gearbox.	Oil seal damaged. Gearbox overfilled.	Replace oil seal. Remove excess oil.

<b>PROBLEM</b>	<b>POSSIBLE CAUSE</b>	<b>SOLUTION</b>
Uneven seed distribution.	Seed cups might be obstructed. Ground speed too fast. Roller not clean.	Check for plugging in seed cup.  Reduce ground speed. Check for trash or mud buildup on roller.
Actual seeding rate is different than desired.	Seed cups might be obstructed.	Seed treatment will affect seeding rate if the chemicals build up in seed cup. Unless cleaned regularly, this buildup can cause breakage of the seed cup shaft.
Seed cup sprocket locked up or twisted seed cup drive shaft.	Seed cups might be obstructed.	Check for foreign matter lodged in seed cup sprocket.
Roller not turning freely.	Roller not clean.	Check for trash or mud buildup on roller end.

## 7 - PRE-DELIVERY CHECKLIST

**To the dealer: Inspect the machine thoroughly after assembly to assure it is functioning properly before delivering it to the customer. The following checklist is a reminder of points to cover. Check off each item as it is found satisfactory or after proper adjustment is made.**

- Gearbox oil level.
- Guards and shield properly fastened.
- Lubrication of grease fittings.
- All hardware properly tightened.
- All decals properly located and readable (**see fig. 2**).
- Blades properly installed, blade bolts and nuts tightened.
- Overall condition (touch up scratches, clean and polish).
- Test run, check for excessive vibration or overheating of bearings.
- Operator's Manual.

**Review the Operator's Manual with the customer. Explain the following:**

- Warranty.
- Safe operation and service.
- Correct machine installation and operation.
- Daily and periodic lubrication, maintenance and inspections.
- Troubleshooting.
- Operational procedures and storage.
- Parts and service.
- Fill out the Pre-Delivery Checklist and Warranty Registration form.
- Give customer the Operator's Manual and encourage the customer to read the manual carefully.

**IMPORTANT: Warranty is not valid unless Pre-Delivery Checklist and Warranty Registration form in Operator's Manual is completed in detail and mailed to the Company.**

Model Number: \_\_\_\_\_

Serial Number: \_\_\_\_\_

Delivery Date: \_\_\_\_\_

Dealer's Signature: \_\_\_\_\_

## 8 - WARRANTY

BEFCO's responsibility will be limited to substitution of the acknowledged defective merchandise to the same place of delivery as the previous one was supplied.

### 1. LIMITED WARRANTY

BEFCO, Inc. herein referred to as the Company, warrants its machines and related accessories, hereafter referred to as the Machine, to be free from defects in material and workmanship, for a period of twelve (12) months from the date of invoice to the first registered owner; this limited warranty does not apply to common wear items and excludes belts, shear pins, oil, grease, tires, tubes, hydraulic hoses, knives and PTO shafts.

Labor will be reimbursed at \$40.00 per hour based on BEFCO's time schedule.

Cost of transport to the servicing dealer is the responsibility of the customer.

Warranty coverage shall not be transferable from the first owner to any subsequent owner.

### 2. DISCLAIMER OF ALL OTHER WARRANTIES AND REMEDIES

Neither the Company nor any company affiliated with the Company makes any warranties, representations or promises, expressed or implied, as to the quality, performance or application of its products other than those set forth herein and does not make any implied warranty of merchantability or fitness.

The only remedies the purchaser has in connection with the breach, or performance of any warranty on the Company's Machine are those set forth herein. In no event will the dealer, the Company, or any company affiliated with the Company, be liable for:

- a. Injuries or damages of any kind or nature, direct, consequential or contingent to person or property.
- b. Any expenses incurred by the owner to repair, replace or rework any allegedly defective item.
- c. Any loss, cost, forfeiture or damages (including loss of profits; loss of crops; loss because of delay in field operations; any expenses or loss incurred for labor, supplies, substitute machine rental; liabilities of the owner to its customers or third persons; and all other consequential damages, losses, liabilities or damages for any other reasons) whether direct or indirect, and whether or not resulting from or contributed to by the default or negligence of the Company, its agents, employees and subcontractors which might be claimed as a result of the use or failure of the equipment delivered.

The Company's liability based on this limited warranty or any other applicable laws shall be limited to replacement or refund of the purchase price of the product.

The limited warranty extended herein gives you specific rights and you may also have other rights which vary from state to state. Neither the dealer nor the Company personnel has the authority to make any representation or to modify the terms and limitations of this warranty in any way.

**Other than the limited warranty extended hereby there is no other expressed warranty in connection with the design, safety or use of any of the Company's products except as to title. All implied warranties are expressly disclaimed pursuant to the terms of this warranty.**

### **3. CUSTOM WORK**

If the Machine is used for commercial purposes such as custom work, the period warranted for the Machine is limited to six (6) months from the date of delivery to the first registered owner and does not cover any labor charges incurred.

### **4. RENTAL**

If the Machine is used for rental purposes the period warranted for the Machine is limited to thirty (30) days from the date of delivery to the first registered owner and does not cover any labor charges incurred.

### **5. REGISTRATION**

In order to qualify for coverage on this limited warranty, the product and name of the original purchaser must be registered with the Company by a completed Machine Pre-Delivery Checklist and Warranty Registration along with a copy of the dealer's invoice to the first registered owner to the Company within fourteen (14) days after the date of delivery to the original purchaser.

### **6. WARRANTY SERVICE**

Warranty Service must be performed by a dealer authorized by BEFCO. If the warranty service requested is approved, the owner shall pay only for labor beyond the rate allowed, for overtime labor, and for any mileage charge for transporting the equipment to and from the dealer's shop. It is assumed that the dealer has the appropriate general and special tools to service the Machine. Time required for replacement of knives, oil, grease and to remove excessive dirt from the Machine is not subject to reimbursement by the Company. The owner is required to clean the Machine before presenting it to the dealer for service work. The Machine must be delivered within thirty (30) days after failure date by the owner to the dealer to be eligible for warranty consideration.

### **7. UNAPPROVED SERVICE OR MODIFICATION**

All obligations of the Company under this limited warranty shall be terminated if:

- a. Proper service and operation instructions as outlined in the Operator's Manual and on the instruction sticker on the Machine, are not followed.
- b. The Machine is modified or altered in any way not approved by the Company.
- c. The Company does not receive a copy of the dealer's invoice to the first registered owner within fourteen (14) days from the date of delivery.
- d. The Company has not been paid in full, by the dealer, for the Machine.

### **8. ACCIDENTS AND NORMAL MAINTENANCE**

This limited warranty covers defective material and workmanship. It does not cover depreciation or damage caused by normal wear, accidents, improper maintenance, improper protection or improper use. The costs of normal maintenance or repairs for accidents or improper use, and related labor will be borne by the owner.

### **9. REPLACEMENT PARTS**

BEFCO, Inc. warrants replacement parts to be free from defect in material and workmanship for a period of thirty (30) days from the date of delivery to the original purchaser.



# WARRANTY REGISTRATION

**BEFCO, Inc.**  
**P.O. Box 6036**  
**Rocky Mount, NC 27802-6036**

**Tel: (252) 977.9920 - Fax: (252) 977.9718**

Dealer _____ Acct. # _____	Retail Customer _____
Street _____ Country _____	Street _____
Town _____ State _____ Zip _____	Town _____ State _____ Zip _____
Date of delivery _____ Invoice # _____	Phone _____
Model # _____ Serial # _____	
<p>Pre-Delivery Checklist:</p> <p><input type="checkbox"/> Oil in gearbox.</p> <p><input type="checkbox"/> Greased fittings.</p> <p><input type="checkbox"/> Safety guards in place.</p> <p><input type="checkbox"/> All hardware tight.</p> <p><input type="checkbox"/> Bolts torqued correctly.</p> <p><input type="checkbox"/> Attached unit to tractor. Yes/No.</p> <p><input type="checkbox"/> Field adjusted. Yes/No.</p> <p><input type="checkbox"/> Test run. Dry/Infield.</p> <p><input type="checkbox"/> Safety decals.</p> <p><input type="checkbox"/> Operator's Manual.</p> <p>The machine described above, had been prepared for delivery according to the Pre-Delivery Checklist and the Customer has been instructed in its care and operation and the condition of warranty.</p>	<p>Tractor make: _____</p> <p>Model: _____; HP _____</p> <p>Type of operation: Private homeowner, Landscaping, Commercial maintenance, Golf Course, Municipality, Turf Farm, others: _____</p> <p>Approximate number of acres machine will be used on annually: _____</p> <p>I hereby acknowledge that:  I have received and accepted delivery of the machine described.  The equipment was checked thoroughly for loose or missing parts and has been adjusted in accordance with the Pre-Delivery Checklist.  I have read and understand the nature and extent of the warranty and understand clearly that there were and are no other representations of warranties either expressed or implied, made by anyone. I have been advised on proper operation, maintenance and lubrication procedure of this equipment.  I have been instructed on and do understand the application, limitation and capacities this equipment was designed and recommended for, all as described in the Operator's Manual and literature published by the Company.</p>
Inspected by: _____	
Date: _____	Date: _____
Dealer's Signature: _____	Customer's Signature: _____

**This registration along with a copy of the invoice must be sent to BEFCO, Inc. within 14 days of date of purchase.**

*Sender:*

*Fold here*

---

*Place stamp  
here*

**BEFCO, Inc.**

Warranty Department

P.O. Box 6036

Rocky Mount, NC 27802-6036

*Cut along this line*

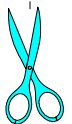







## **Use only original spare parts**

*All rights reserved. It is unlawful to copy, reprint or use any of the information or details in this manual without the expressed written permission of the Company. Technical information provided in this manual is approximate, the Company reserves the right to modify or improve the models shown for technical or commercial purposes. Pictures in this manual do not necessarily show the machine as delivered.*

---

**BEFCO**<sup>®</sup>

P.O. Box 6036  
Rocky Mount, NC 27802-6036  
Tel.: 252.977.9920 - Fax: 252.977.9718  
[www.befco.com](http://www.befco.com)

