

Machine type: SHREDDER

Document ID: 902621001

Model: TUF

Revision: 03_15/06/2019 ->

Group: Tractor hitches

Table: 01

Reference	P/N	Description	Model #	Quantity
1	5137068	RC/SA coupling support hook clip		1
2	3614100008	Wide washer UNI6593 100Hv Øi08 galvanised		1
3	3021108016	Screw UNI5739 8.8 M8x16 galvanised (coarse pitch)		1
4	3464101008	UNI7473 (coarse pitch) M8 zinc plated nut		1
5	4337002	200 hook for shaft drive		1
6	6350010	Snap pin DIN11023 D10 galvanised		1
7	5304435	SPR/TRG/TR 3rd point pin Ø25		1
8	5007422	Mobile arc		1
9	6037683	Male quick-hitch 1/2"		1
10	6470012	Washer Cu 1/2		1
11	6037390	Nipple 1/2" 3/8"		1
12	6492250	Rubber hose R1-3/8 C/Md-2500		1
13	6492200	Rubber hose R1-3/8 C/Md-2000		1
14	3011116100	Screw UNI5737 8.8 M16x100 galvanised (coarse pitch)		1
15	3021116025	Screw UNI5739 8.8 M16x25 galvanised (coarse pitch)		1
16	3635100016	Grower Fiat washer 10188 C70 Ø16 zinc plated		1
17	5336326	TRX/TR/TUF moving scroll		1
18	6330640	Elastic pin Ø6x40 UNI6873 galvanised		1
19	5206324	Lateral moving bushing		1
20	3604100024	Flat washer M24 UNI6592		1
21	5007436	370 TUF stroke piston	TUF/155/180	1
21	5007437	450 TUF stroke piston	TUF/200/220/250	1
22	4002473	Screw for movement	TUF/155	1
22	4002474	Screw for movement	TUF/180	1
22	4002475	M24x3 screw SD185 moving	TUF/200/220/250	1
23	4002235	SD/TUF/TRX crank		1
24	3424101016	UNI5588 M16 (coarse pitch) zinc plated nut		1
25	5217401	TUF arc shaped roller		1
26	3424101018	Nut M18 UNI5588		1
27	3011116110	Screw UNI5737 8.8 M16x110 galvanised (coarse pitch)		1
28	5304073	FB/TZF lower pin Cat.2		1
29	5534002	FB/TZF short spacer tube		1
30	5004034	FB/TZF bout cup		1
31	5007438	TUF155/180 piston jacket		1
32	5007439	TUF200/220/250 piston jacket		1
32	6310053	Elastic ring Ø53 UNI7437 DIN472		1
33	6038325	WRM 098129 scraper		1
34	5007440	Piston rod		1
35	5242372	FL10E/15E/-ETS/SD/.../TRX bearing holder ring		1
36	6836827	O-ring 617 2,62x17,86		1
37	6836120	O-ring 2,62x25x30		1
38	6838029	Gasket B129098/1		1
39	6836617	O-ring 617 2,62x17,86		1
40	5202373	TR/FB/TSP/TRX piston		1
41	6838283	Gasket DBM196133		1

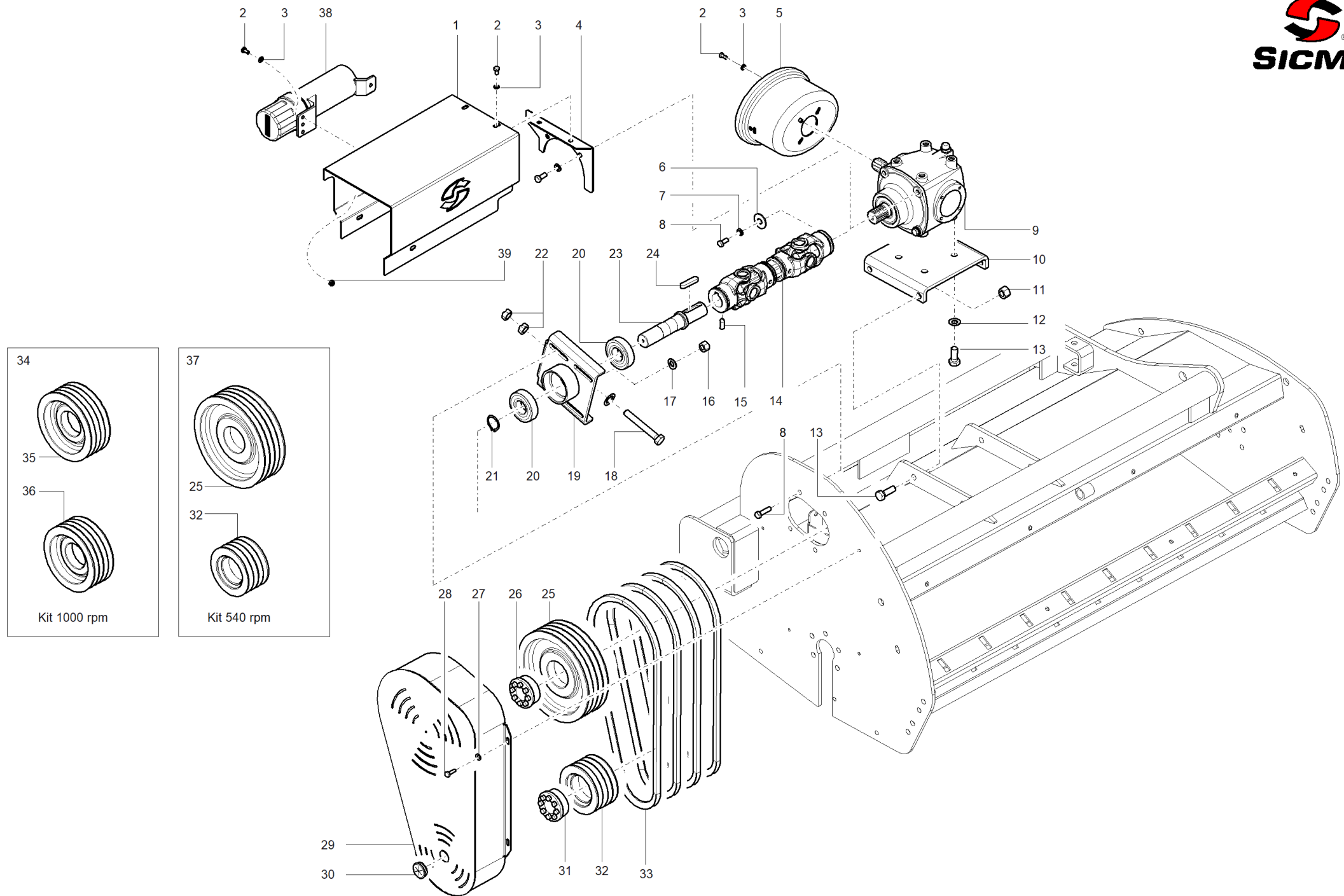

Machine type: SHREDDER

Document ID: 902621001

Model: TUF

Revision: 03_15/06/2019 ->

Group: SIDE TRANSMISSION

Table: 02

Reference	P/N	Description	Model #	Quantity
1	5137457	Drive shaft guard	TUF/155	1
1	5137458	Drive shaft guard	TUF/180	1
1	5137459	Drive shaft guard	TUF/200*220*250	1
2	3021108016	Screw UNI5739 8.8 M8x16 galvanised (coarse pitch)		12
3	3614100008	Wide washer UNI6593 100Hv Øi08 galvanised		12
4	5137460	Unit side transmission shaft guard support		1
5	1883512	Counter-cone		1
6	1201065	FB blocking washer		1
7	3625100012	Grower washer DIN1751 C70 Øi12 zinc plated		1
8	3021112030	Screw UNI5739 8.8 M12x30 galvanised (coarse pitch)		1
9	8060001	EC60 R.2/1 1/PTO+free wheel gearbox		1
10	5937413	Multiplier support plate		1
11	3464101016	UNI7473 (coarse pitch) M16 zinc plated nut		4
12	3604100016	Flat washer UNI6592 140Hv Øi16 galvanised		4
13	3021116035	Screw TE M16x35 UNI5739		8
14	E7255000	Driveshaft AX5F 320/506 1705111-1065015 SP		1
14	E7255006	Driveshaft AX5F 370/556 1705111-1065015 SP		1
14	EAX55000-0049	Driveshaft AX5F 220/406 1705111-1065015 SP		1
15	31112020	Grub screw 12X20 coarse pitch UNI5927		1
16	3464101012	UNI7473 (coarse pitch) M12 zinc plated nut		4
17	3614100012	Wide washer UNI6593 100Hv Øi12 galvanised		4
18	3011114110	Screw TE UNI5737 M14x110		1
19	5004400	TRG/TR driving pulley support		1
20	2226308	6308 2RS bearing		2
21	6320040	Elastic ring Ø40 UNI7435 DIN471		1
22	3464101014	UNI7473 (coarse pitch) M14 zinc plated nut		2
23	5214167	FB/TR driving pulley shaft		1
24	6361270	12x70x8 UNI6604 key		1
25	5643005	Pulley vibik spb 300/4 grooves		1
26	6364080	VK 156 40/80 shrink disc		1
27	3021108025	Screw UNI5739 8.8 M8x25 galvanised (coarse pitch)		4
28	3021108025	Screw UNI5739 8.8 M8x25 galvanised (coarse pitch)		4
29	5007434	TUF belt crankcase		1
30	6603516	Ø35x16 cap with opening for greaser		1
31	6364580	VK 156 45/80 shrink disc		1
32	5644132	Vibik spb 140/4 grooves		1
33	6721500	XPB-1500 toothed belt		4
34	8621021	Drive kit @1000rpm		1
35	5645103	Pulley vibik spb 236x4 Ø80		1
36	5644143	Pulley vibik spb 212/4 grooves (1000 rpm)		1
37	8621020	Drive kit @540rpm		1
38	6601601	Document holder container - large		1
39	3464101008	UNI7473 (coarse pitch) M8 zinc plated nut		1

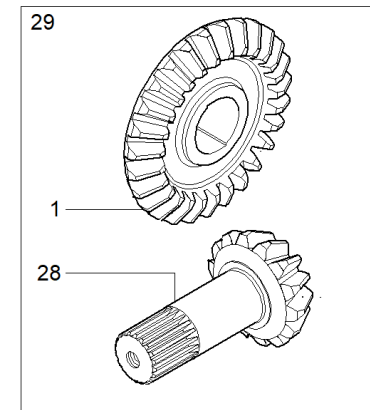
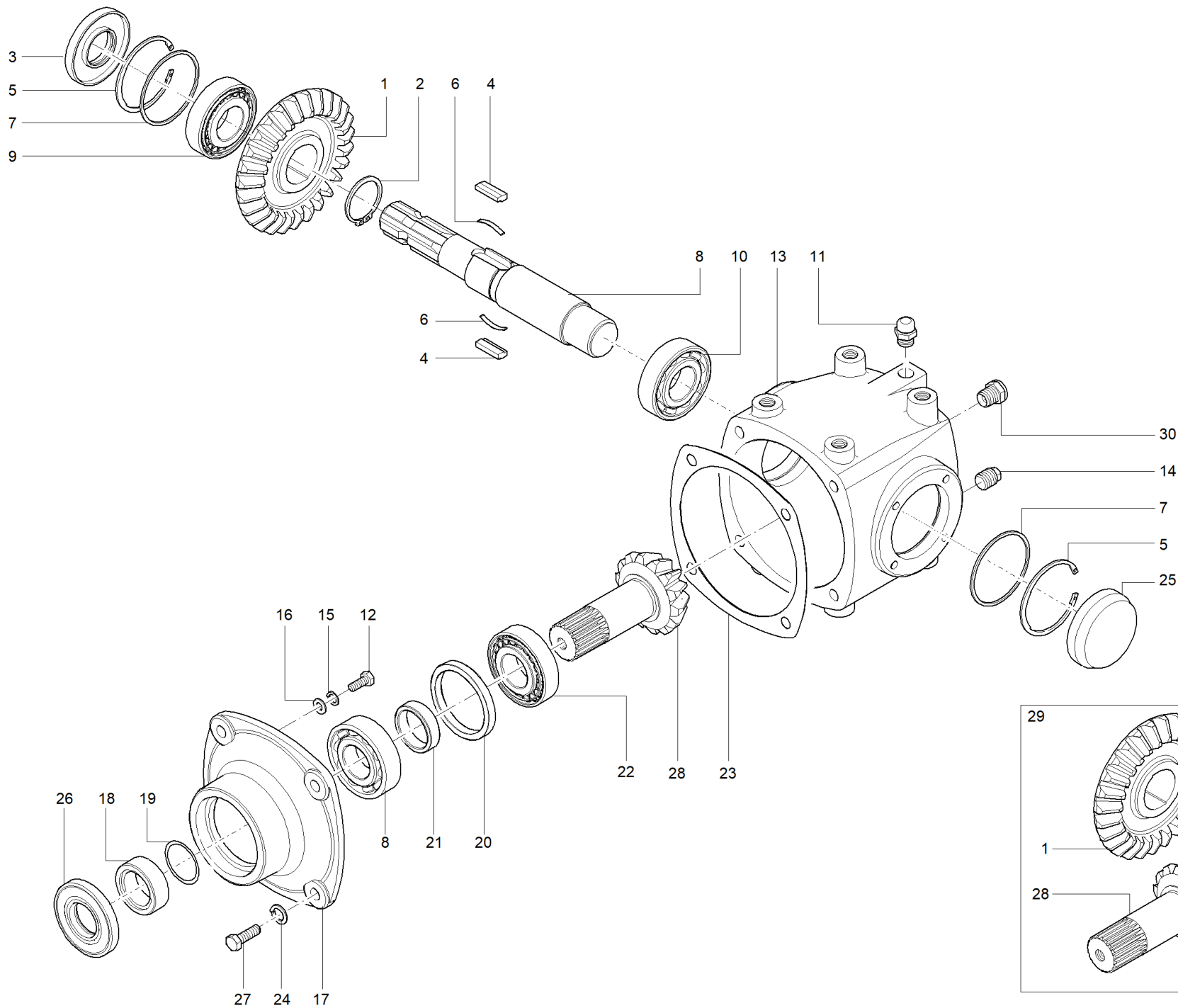

Machine type: SHREDDER

Model: TUF

Group: GEARBOX

Document ID: 902621001

Revision: 03 _15/06/2019 ->

Table: 03

Reference	P/N	Description	Model #	Quantity
1	1721076	Z27 conical crown TUF/TR free wheel		1
2	6320042	Elastic ring Ø42 UNI7435 DIN471		1
3	6103580	35x80x12 GM DIN3760 A-type oil seal		1
4	1321001	EC60 free wheel stud		1
5	6310080	Elastic ring Ø80 UNI7437 DIN472		1
6	1811001	Flat spring		1
7	6017002	70x80x0,2 shim		1
8	1221003	Freewheel extension shaft		1
9	2030307	30307 bearing		1
10	2006208	6208 bearing		1
11	3442018	18X1.5 cylindrical valve cap		1
12	30208025	Screw TE M8x25 UNI5739		1
13	1641001	EC60 gearbox crankcase		1
14	3441018	18x1.5 conical cap (hexagon socket)		1
15	3625100008	Grower washer DIN1751 C70 Øi8 zinc plated		1
16	3604100008	Flat washer UNI6592 140Hv Øi08 galvanised		1
17	1701066	FB/TR sprocket support		1
18	1591073	OR824 door spacer		1
19	6836824	O-ring seal 824 D36,69x3,53		1
20	1591068	External ring bearing spacer		1
21	4593020	VM/ZLS connecting rod end oil seal bushing		1
22	2730208	30208 bearing		1
23	1781041	EC60 crankcase seal		1
24	3625100012	Grower washer DIN1751 C70 Øi12 zinc plated		1
25	6100080	Locking screw cap, Ø80 H=10		1
26	6106085	Oil seal 60x85x10 lawnmower DIN3760, A type		1
27	3021112030	Screw UNI5739 8.8 M12x30 galvanised (coarse pitch)		1
28	1721074	Z14 TUF/TR conical sprocket		1
29	8020012	EC60 bevel gear kit R.2:1 for free wheel		1
30	3444118	M18x1.5 conical porthole cap without washer		1

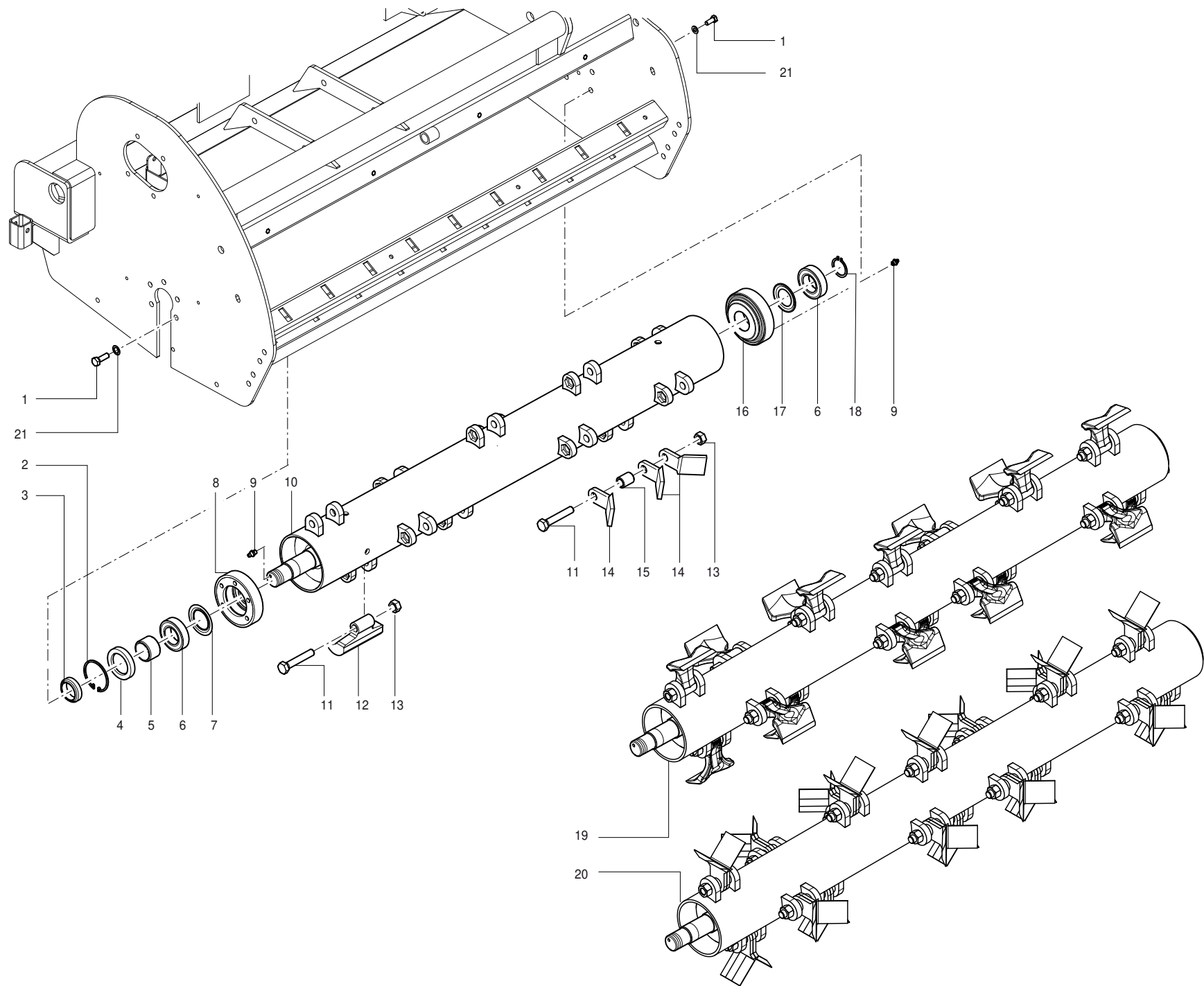

Machine type: SHREDDER

Document ID: 902621001

Model: TUF

Revision: 03_15/06/2019 ->

Group: ROTOR AND TOOLS

Table: 04

Reference	P/N	Description	Model #	Quantity
17	2022210	22210/AV Nilos		1
7	2122210	22210/JV Nilos		1
6	2822210	22210 bearing		2
11	3011020120	TE UNI 5737 screw, coarse pitch 8.8 M20x120	TUF/155	12
11	3011020120	TE UNI 5737 screw, coarse pitch 8.8 M20x120	TUF/180	14
11	3011020120	TE UNI 5737 screw, coarse pitch 8.8 M20x120	TUF/200	16
11	3011020120	TE UNI 5737 screw, coarse pitch 8.8 M20x120	TUF/220	18
11	3011020120	TE UNI 5737 screw, coarse pitch 8.8 M20x120	TUF/250	20
1	3022114030			5
3	34127050	50x1.5 high self-locking ring		1
13	3464101020	UNI7473 (coarse pitch) M20 zinc plated nut	TUF/155	12
13	3464101020	UNI7473 (coarse pitch) M20 zinc plated nut	TUF/180	14
13	3464101020	UNI7473 (coarse pitch) M20 zinc plated nut	TUF/250	20
13	3464101020	UNI7473 (coarse pitch) M20 zinc plated nut	TUF/200	16
13	3464101020	UNI7473 (coarse pitch) M20 zinc plated nut	TUF/220	18
21	3645200014	Schnorr Washer Ø14		10
10	5007425	TUF155 rotor	TUF/155	1
20	5007425C	TUF155 balanced rotor with knives	TUF/155	1
19	5007425ML	TUF155 balanced rotor with smooth hammers	TUF/155	1
10	5007426	TUF180 rotor	TUF/180	1
20	5007426C	TUF180 balanced rotor with knives	TUF/180	1
19	5007426ML	TUF180 balanced rotor with smooth hammers	TUF/180	1
10	5007427	TUF200 rotor	TUF/200	1
20	5007427C	TUF200 balanced rotor with knives	TUF/200	1
19	5007427ML	TUF200 balanced rotor with smooth hammers	TUF/200	1
10	5007428	TUF220 rotor	TUF/220	1
20	5007428C	TUF220 balanced rotor with knives	TUF/220	1
19	5007428ML	TUF220 balanced rotor with smooth hammers	TUF/220	1
10	5007429	TUF250 rotor	TUF/250	1
20	5007429C	TUF250 balanced rotor with knives	TUF/250	1
19	5007429ML	TUF250 balanced rotor with smooth hammers	TUF/250	1
8	5007443	TUF transmission side rotor support		1
16	5007444	TUF external side rotor support		1
15	5536275	FB/TUF knife spacer bushing	TUF/220	18
15	5536275	FB/TUF knife spacer bushing	TUF/250	20
15	5536275	FB/TUF knife spacer bushing	TUF/155	12
15	5536275	FB/TUF knife spacer bushing	TUF/180	14
15	5536275	FB/TUF knife spacer bushing	TUF/200	16
5	5536510	Ø60 L=38 TR/TZF duct pulley spacer		1
4	6106090	Oil seal 60x90x10 lawnmower DIN3760, A type		1
2	6310090	Elastic ring Ø90 UNI7437 DIN472		1
18	6320050	Elastic ring Ø50 UNI7435 DIN471		1
9	6560010	Type-A greaser UNI7663 M10x1.5		2
12	5715104S	RM Ø85 SL/SL-Q/TSN/TSN-Q/FB/TUF trip hammer (in 10x box)	TUF/155	12
14	5816274S	"Y" TS/TSP/TSN/TZF/TUF/SL/FB knife (in 20x box)	TUF/155	36
12	5715104S	RM Ø85 SL/SL-Q/TSN/TSN-Q/FB/TUF trip hammer (in 10x box)	TUF/180	14
14	5816274S	"Y" TS/TSP/TSN/TZF/TUF/SL/FB knife (in 20x box)	TUF/180	42
12	5715104S	RM Ø85 SL/SL-Q/TSN/TSN-Q/FB/TUF trip hammer (in 10x box)	TUF/200	16
14	5816274S	"Y" TS/TSP/TSN/TZF/TUF/SL/FB knife (in 20x box)	TUF/200	48
12	5715104S	RM Ø85 SL/SL-Q/TSN/TSN-Q/FB/TUF trip hammer (in 10x box)	TUF/220	18
14	5816274S	"Y" TS/TSP/TSN/TZF/TUF/SL/FB knife (in 20x box)	TUF/220	54
12	5715104S	RM Ø85 SL/SL-Q/TSN/TSN-Q/FB/TUF trip hammer (in 10x box)	TUF/250	20
14	5816274S	"Y" TS/TSP/TSN/TZF/TUF/SL/FB knife (in 20x box)	TUF/250	60

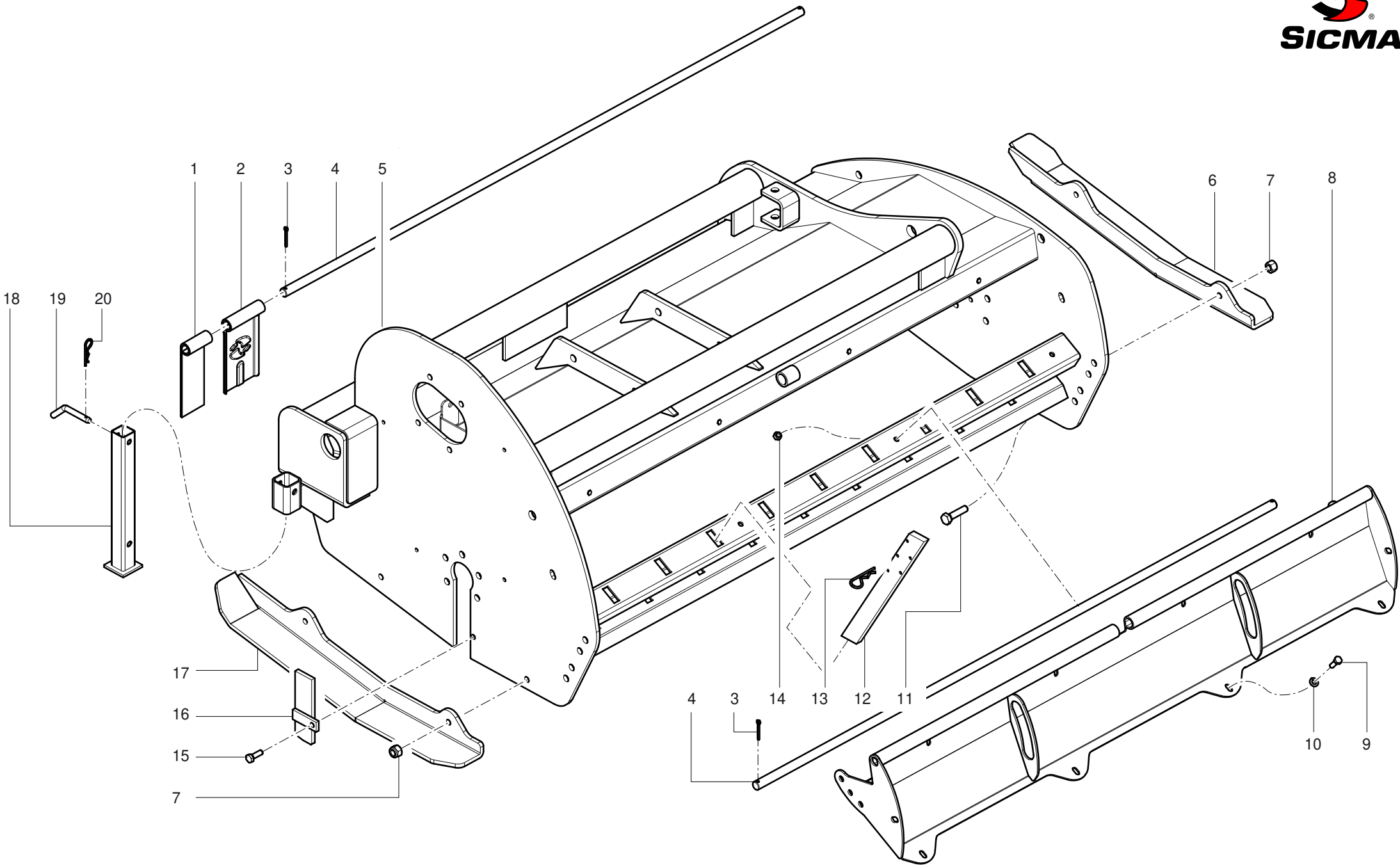

Machine type: SHREDDER

Document ID: 902621001

Model: TUF

Revision: 03_15/06/2019 ->

Group: FRAME AND GUARDS

Table: 05

Reference	P/N	Description	Model #	Quantity
1	5136125	PALETTA STRET.40x225 D.22(2019)NO LOGO	TUF/250	1
2	5136117	-PALETTA 110x225 D.22 (2019) LOGO	TUF/155	14
2	5136117	-PALETTA 110x225 D.22 (2019) LOGO	TUF/180	16
2	5136117	-PALETTA 110x225 D.22 (2019) LOGO	TUF/200	18
2	5136117	-PALETTA 110x225 D.22 (2019) LOGO	TUF/250	22
3	6340550	Split pin UNI1336 5x50 Untreated		4
4	5236062	TS155 pallet pivot	TUF/180	2
4	5237001	TZF180 pallet pivot	TUF/200	2
4	5237002	TZF200 pallet pivot	TUF/220	2
4	5237003	TZF220 pallet pivot	TUF/250	2
4	5237004	TZF250 pallet pivot	TUF/155	2
5	5007401	Body	TUF/155	1
5	5007402	Body	TUF/250	1
5	5007403	Body	TUF/200	1
5	5007404	Body	TUF/220	1
5	5007405	Body	TUF/180	1
6	5137042	TZF right slide		1
7	3464101014	UNI7473 (coarse pitch) M14 zinc plated nut		4
8	5007415	Fixed lid	TUF/155	1
8	5007416	Fixed lid	TUF/180	1
8	5007417	Fixed lid	TUF/200	1
8	5007418	Fixed lid	TUF/220	1
8	5007419	Fixed lid	TUF/250	1
9	3021110020	Screw UNI5739 8.8 M10x20 galvanised (coarse pitch)	TUF/155•180	4
9	3021110020	Screw UNI5739 8.8 M10x20 galvanised (coarse pitch)	TUF/200	5
9	3021110020	Screw UNI5739 8.8 M10x20 galvanised (coarse pitch)	TUF/220•250	6
10	3614100010	Wide washer UNI6593 100Hv Øi10 galvanised	TUF/220•250	6
10	3614100010	Wide washer UNI6593 100Hv Øi10 galvanised	TUF/155•180	4
10	3614100010	Wide washer UNI6593 100Hv Øi10 galvanised	TUF/200	5
11	3021112035	Screw UNI5739 8.8 M12x35 galvanised (coarse pitch)		4
12	5836084	TUF/SL/TZF crampons	TUF/250	15
12	5836084	TUF/SL/TZF crampons	TUF/155	9
12	5836084	TUF/SL/TZF crampons	TUF/200	12
12	5836084	TUF/SL/TZF crampons	TUF/180	11
12	5836084	TUF/SL/TZF crampons	TUF/220	13
13	6351005	Split pin Ad R Ø5 galvanised	TUF/155	9
13	6351005	Split pin Ad R Ø5 galvanised	TUF/250	15
13	6351005	Split pin Ad R Ø5 galvanised	TUF/200	12
13	6351005	Split pin Ad R Ø5 galvanised	TUF/180	11
13	6351005	Split pin Ad R Ø5 galvanised	TUF/220	13
14	3464101012	UNI7473 (coarse pitch) M12 zinc plated nut	TUF/155•180	4
14	3464101012	UNI7473 (coarse pitch) M12 zinc plated nut	TUF/200	5
14	3464101012	UNI7473 (coarse pitch) M12 zinc plated nut	TUF/220•250	6
15	3021110030	Screw UNI5739 8.8 M10x30 galvanised (coarse pitch)		1
16	5007435	Transmission slot closure		1
17	5137043	TZF left slide		1
18	5007046	TZF support foot		1
19	4236115	SA/SB/CS/ZLL/RM foot locking pin		1
20	6351004	Split pin Ad R Ø4 galvanised		1

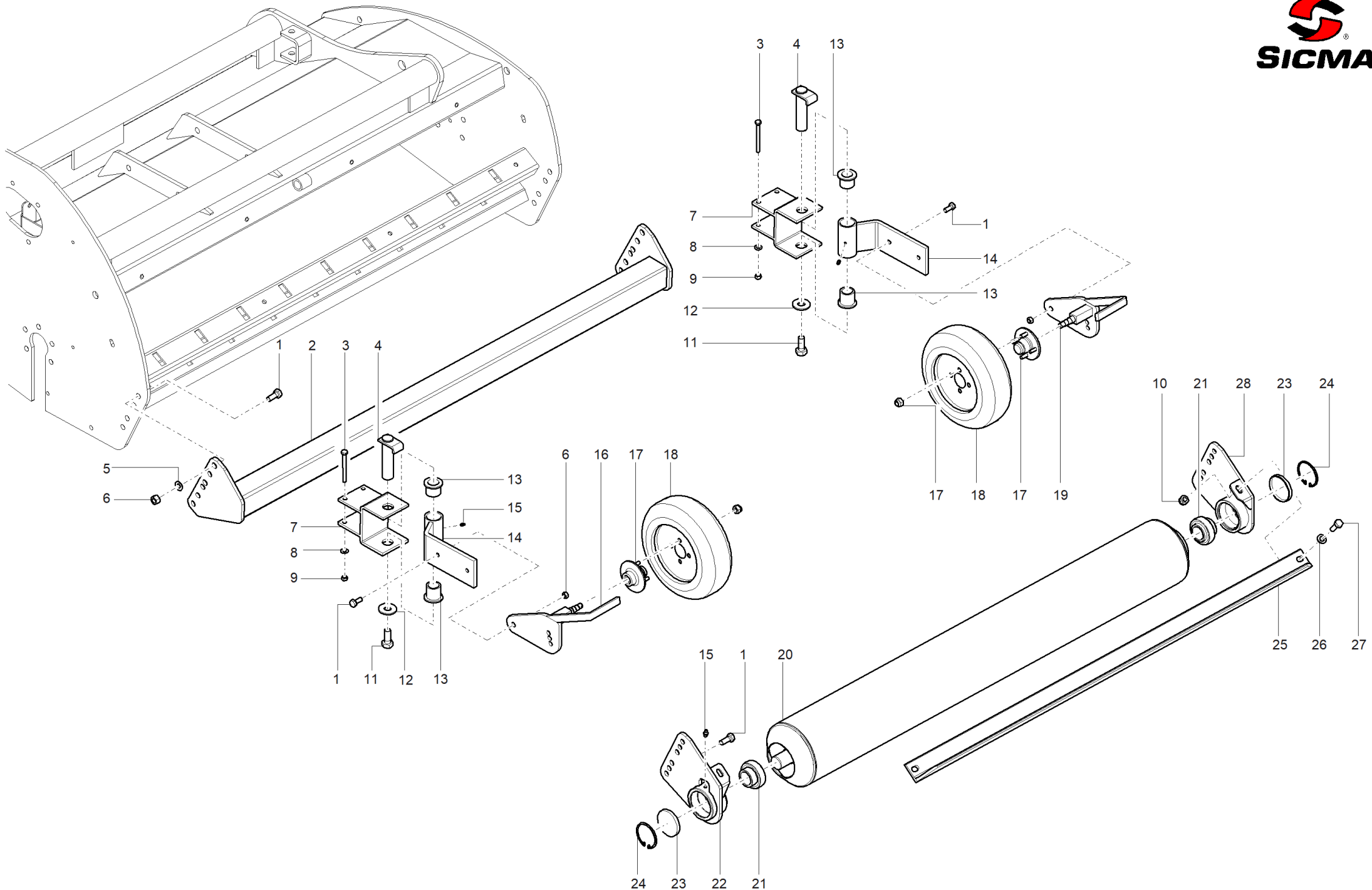

Machine type: SHREDDER

Document ID: 902621001

Model: TUF

Revision: 03_15/06/2019 ->

Group: REAR WHEELS AND ROLLER

Table: 06

Reference	P/N	Description	Model #	Quantity
1	3021114030	Screw UNI5739 8.8 M14x30 galvanised (coarse pitch)		1
2	5007445	TUF155 wheel support	TUF/155	1
2	5007446	TUF180 wheel support	TUF/180	1
2	5007447	TUF200 wheel support	TUF/200	1
2	5007448	TUF220 wheel support	TUF/220	1
2	5007449	TUF250 wheel support	TUF/250	1
3	3021110100	Screw TE M10x100 UN I5739		1
4	4005406	TS/TRX/TLX rotating pivot		1
5	341020014	Flat washer UNI6592 Ø14		1
6	3464101014	UNI7473 (coarse pitch) M14 zinc plated nut		1
7	4005390	TS/TRX junction support		1
8	341020010	Flat washer Ø10 UNI6592		1
9	3464101010	UNI7473 (coarse pitch) M10 zinc plated nut		1
10	3464101014	UNI7473 (coarse pitch) M14 zinc plated nut		1
11	3021114025	Screw TE M14x25 UNI5739		1
12	34118114	Wide washer UNI6593		1
13	5706890	Pivoting wheel sintered bushing		1
14	4005335	Wheel support boom		1
15	6560008	Type-A greaser UNI7663 M8x1.25		1
16	4005336	Lh wheel support		1
17	5846882	Complete 35 panel 4-hole spring		1
18	6610500	Wheel 145-10 6 tele Ø490		1
19	4005337	Rh wheel support		1
20	5007025	TUF/TZF180 stabilising roller	TUF/180	1
20	5007026	TUF/TZF200 stabilising roller	TUF/200	1
20	5007027	TUF/TZF220 stabilising roller	TUF/220	1
20	5007028	TUF/TZF250 stabilising roller	TUF/250	1
20	5007442	TUF155 stabilising roller	TUF/155	1
21	2030040	UC208 bearing		1
22	5007048	Left support roller TUF/TZF		1
23	6100080	Locking screw cap, Ø80 H=10		1
24	6311080	Ø80 SB internal ring		1
25	5857001	TZF180 roller scraper	TUF/180	1
25	5857002	TZF200 roller scraper	TUF/200	1
25	5857003	TZF220 roller scraper	TUF/220	1
25	5857004	TZF250 roller scraper	TUF/250	1
25	5857401	TUF155 roller scraper	TUF/155	1
26	3614100014	Wide washer UNI6593 100Hv Øi14 galvanised		1
27	3021114035	Screw UNI5739 8.8 M14x35 galvanised (coarse pitch)		1
28	5007049	TZF Rh roller support		1

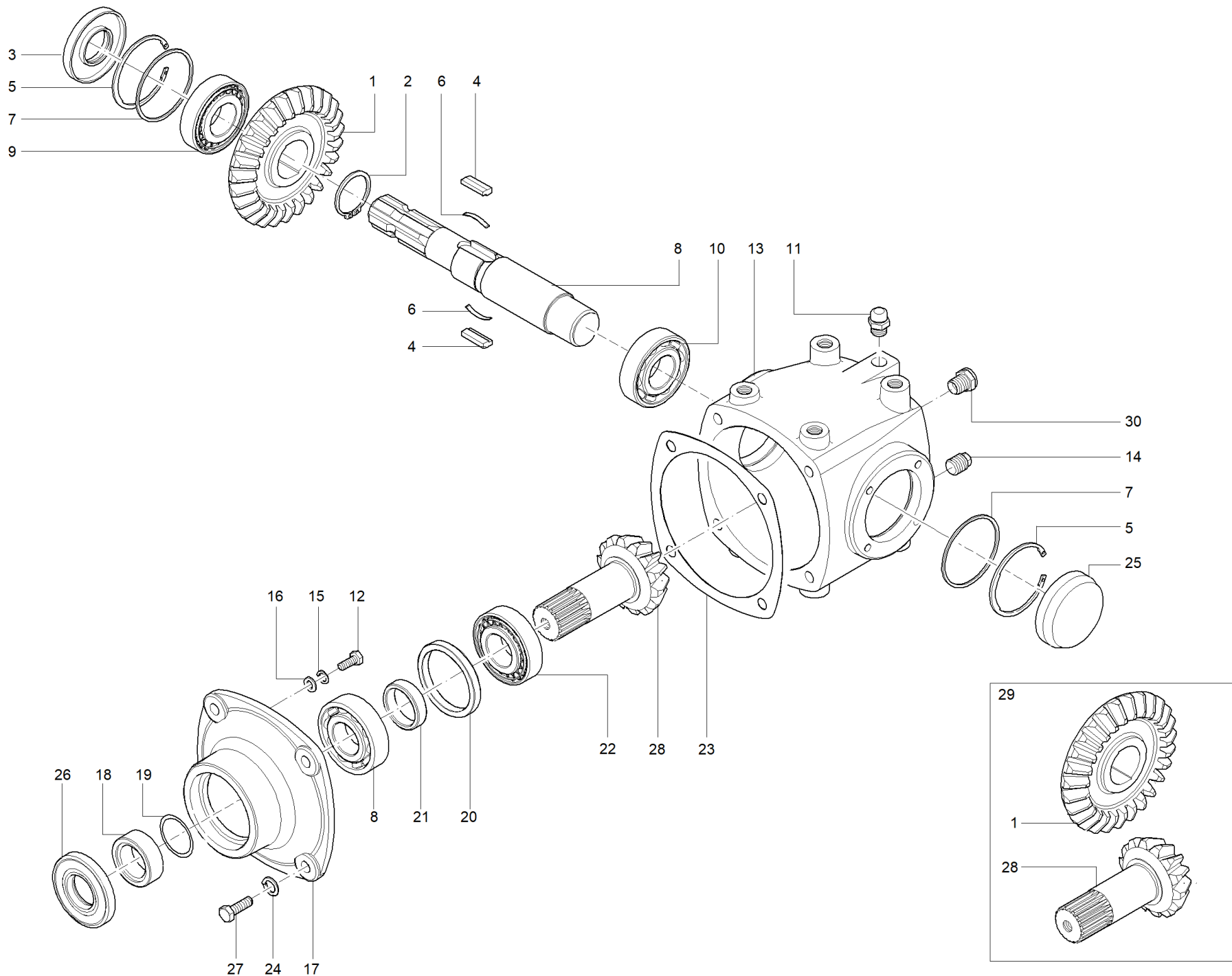

Machine type: SHREDDER

Model: TUF

Group: GEARBOX

Document ID: 902621001

Revision: 02_09/02/2017 - 15/06/2019

Table: 03

Reference	P/N	Description	Model #	Quantity
1	1721076	Z27 conical crown TUF/TR free wheel		1
2	6320042	Elastic ring Ø42 UNI7435 DIN471		1
3	6103580	35x80x12 GM DIN3760 A-type oil seal		1
4	1321001	EC60 free wheel stud		1
5	6310080	Elastic ring Ø80 UNI7437 DIN472		1
6	1811001	Flat spring		1
7	6017002	70x80x0,2 shim		1
8	1221003	Freewheel extension shaft		1
9	2030307	30307 bearing		1
10	2006208	6208 bearing		1
11	3442018	18X1.5 cylindrical valve cap		1
12	30208025	Screw TE M8x25 UNI5739		1
13	1641001	EC60 gearbox crankcase		1
14	3441018	18x1.5 conical cap (hexagon socket)		1
15	3625100008	Grower washer DIN1751 C70 Øi8 zinc plated		1
16	3604100008	Flat washer UNI6592 140Hv Øi08 galvanised		1
17	1701066	FB/TR sprocket support		1
18	1591073	OR824 door spacer		1
19	6836824	O-ring seal 824 D36,69x3,53		1
20	1591068	External ring bearing spacer		1
21	4593020	VM/ZLS connecting rod end oil seal bushing		1
22	2730208	30208 bearing		1
23	1781041	EC60 crankcase seal		1
24	3625100012	Grower washer DIN1751 C70 Øi12 zinc plated		1
25	6100080	Locking screw cap, Ø80 H=10		1
26	6106085	Oil seal 60x85x10 lawnmower DIN3760, A type		1
27	3021112030	Screw UNI5739 8.8 M12x30 galvanised (coarse pitch)		1
28	1721074	Z14 TUF/TR conical sprocket		1
29	8020012	EC60 bevel gear kit R.2:1 for free wheel		1
30	3444118	M18x1.5 conical porthole cap without washer		1

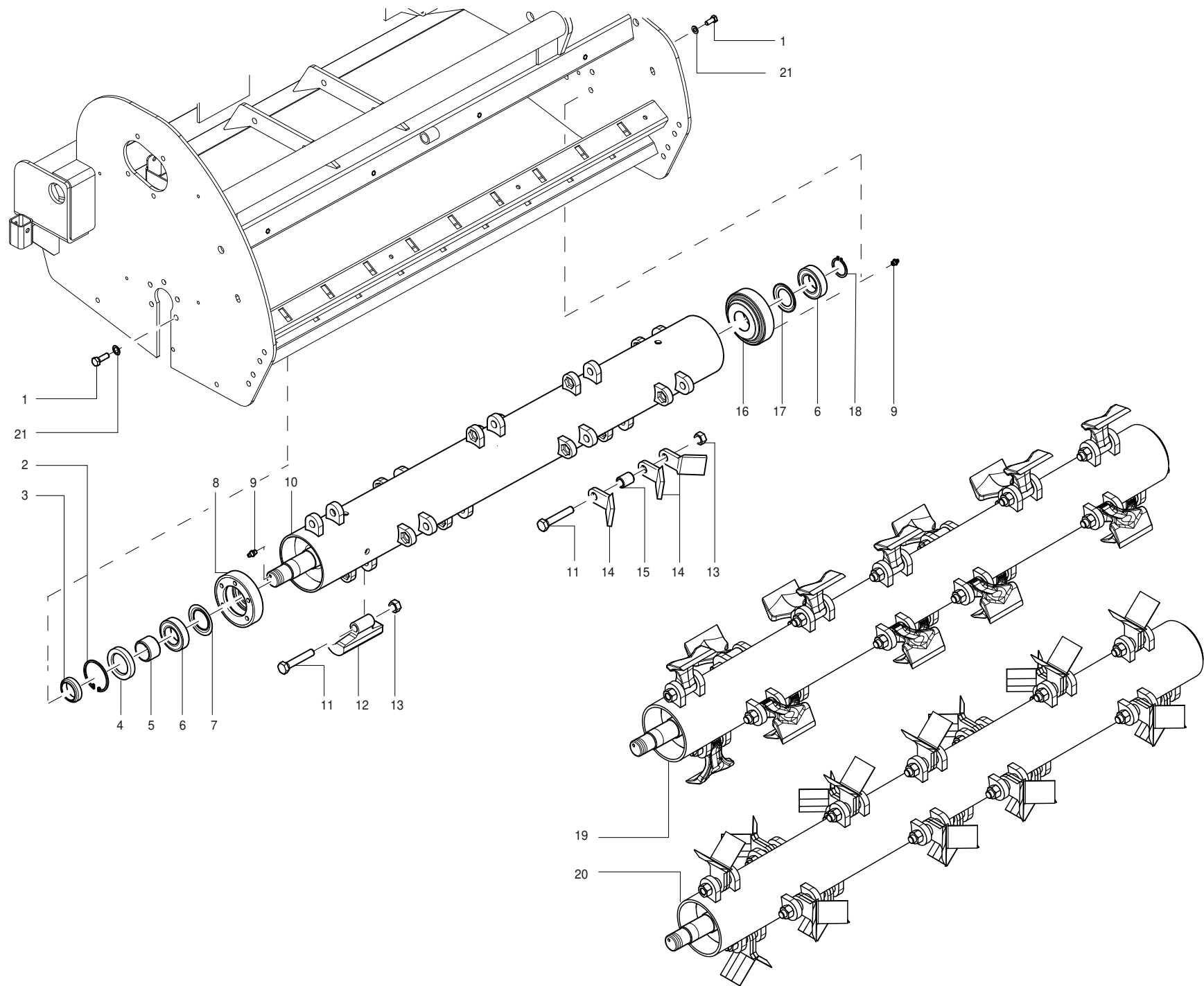

Machine type: SHREDDER

Document ID: 902621001

Model: TUF

Revision: 02_09/02/2017 - 15/06/2019

Group: ROTOR AND TOOLS

Table: 04

Reference	P/N	Description	Model #	Quantity
17	2022210	22210/AV Nilos		1
7	2122210	22210/JV Nilos		1
6	2822210	22210 bearing		2
11	3011020120	TE UNI 5737 screw, coarse pitch 8.8 M20x120	TUF/155	12
11	3011020120	TE UNI 5737 screw, coarse pitch 8.8 M20x120	TUF/180	14
11	3011020120	TE UNI 5737 screw, coarse pitch 8.8 M20x120	TUF/200	16
11	3011020120	TE UNI 5737 screw, coarse pitch 8.8 M20x120	TUF/220	18
11	3011020120	TE UNI 5737 screw, coarse pitch 8.8 M20x120	TUF/250	20
1	3022114030			5
3	34127050	50x1.5 high self-locking ring		1
13	3464101020	UNI7473 (coarse pitch) M20 zinc plated nut	TUF/155	12
13	3464101020	UNI7473 (coarse pitch) M20 zinc plated nut	TUF/180	14
13	3464101020	UNI7473 (coarse pitch) M20 zinc plated nut	TUF/250	20
13	3464101020	UNI7473 (coarse pitch) M20 zinc plated nut	TUF/200	16
13	3464101020	UNI7473 (coarse pitch) M20 zinc plated nut	TUF/220	18
21	3645200014	Schnorr Washer Ø14		10
10	5007425	TUF155 rotor	TUF/155	1
20	5007425C	TUF155 balanced rotor with knives	TUF/155	1
19	5007425ML	TUF155 balanced rotor with smooth hammers	TUF/155	1
10	5007426	TUF180 rotor	TUF/180	1
20	5007426C	TUF180 balanced rotor with knives	TUF/180	1
19	5007426ML	TUF180 balanced rotor with smooth hammers	TUF/180	1
10	5007427	TUF200 rotor	TUF/200	1
20	5007427C	TUF200 balanced rotor with knives	TUF/200	1
19	5007427ML	TUF200 balanced rotor with smooth hammers	TUF/200	1
10	5007428	TUF220 rotor	TUF/220	1
20	5007428C	TUF220 balanced rotor with knives	TUF/220	1
19	5007428ML	TUF220 balanced rotor with smooth hammers	TUF/220	1
10	5007429	TUF250 rotor	TUF/250	1
20	5007429C	TUF250 balanced rotor with knives	TUF/250	1
19	5007429ML	TUF250 balanced rotor with smooth hammers	TUF/250	1
8	5007443	TUF transmission side rotor support		1
16	5007444	TUF external side rotor support		1
15	5536275	FB/TUF knife spacer bushing	TUF/220	18
15	5536275	FB/TUF knife spacer bushing	TUF/250	20
15	5536275	FB/TUF knife spacer bushing	TUF/155	12
15	5536275	FB/TUF knife spacer bushing	TUF/180	14
15	5536275	FB/TUF knife spacer bushing	TUF/200	16
5	5536510	Ø60 L=38 TR/TZF duct pulley spacer		1
4	6106090	Oil seal 60x90x10 lawnmower DIN3760, A type		1
2	6310090	Elastic ring Ø90 UNI7437 DIN472		1
18	6320050	Elastic ring Ø50 UNI7435 DIN471		1
9	6560010	Type-A greaser UNI7663 M10x1.5		2
12	5715104S	RM Ø85 SL/SL-Q/TSN/TSN-Q/FB/TUF trip hammer (in 10x box)	TUF/155	12
14	5816274S	"Y" TS/TSP/TSN/TZF/TUF/SL/FB knife (in 20x box)	TUF/155	36
12	5715104S	RM Ø85 SL/SL-Q/TSN/TSN-Q/FB/TUF trip hammer (in 10x box)	TUF/180	14
14	5816274S	"Y" TS/TSP/TSN/TZF/TUF/SL/FB knife (in 20x box)	TUF/180	42
12	5715104S	RM Ø85 SL/SL-Q/TSN/TSN-Q/FB/TUF trip hammer (in 10x box)	TUF/200	16
14	5816274S	"Y" TS/TSP/TSN/TZF/TUF/SL/FB knife (in 20x box)	TUF/200	48
12	5715104S	RM Ø85 SL/SL-Q/TSN/TSN-Q/FB/TUF trip hammer (in 10x box)	TUF/220	18
14	5816274S	"Y" TS/TSP/TSN/TZF/TUF/SL/FB knife (in 20x box)	TUF/220	54
12	5715104S	RM Ø85 SL/SL-Q/TSN/TSN-Q/FB/TUF trip hammer (in 10x box)	TUF/250	20
14	5816274S	"Y" TS/TSP/TSN/TZF/TUF/SL/FB knife (in 20x box)	TUF/250	60

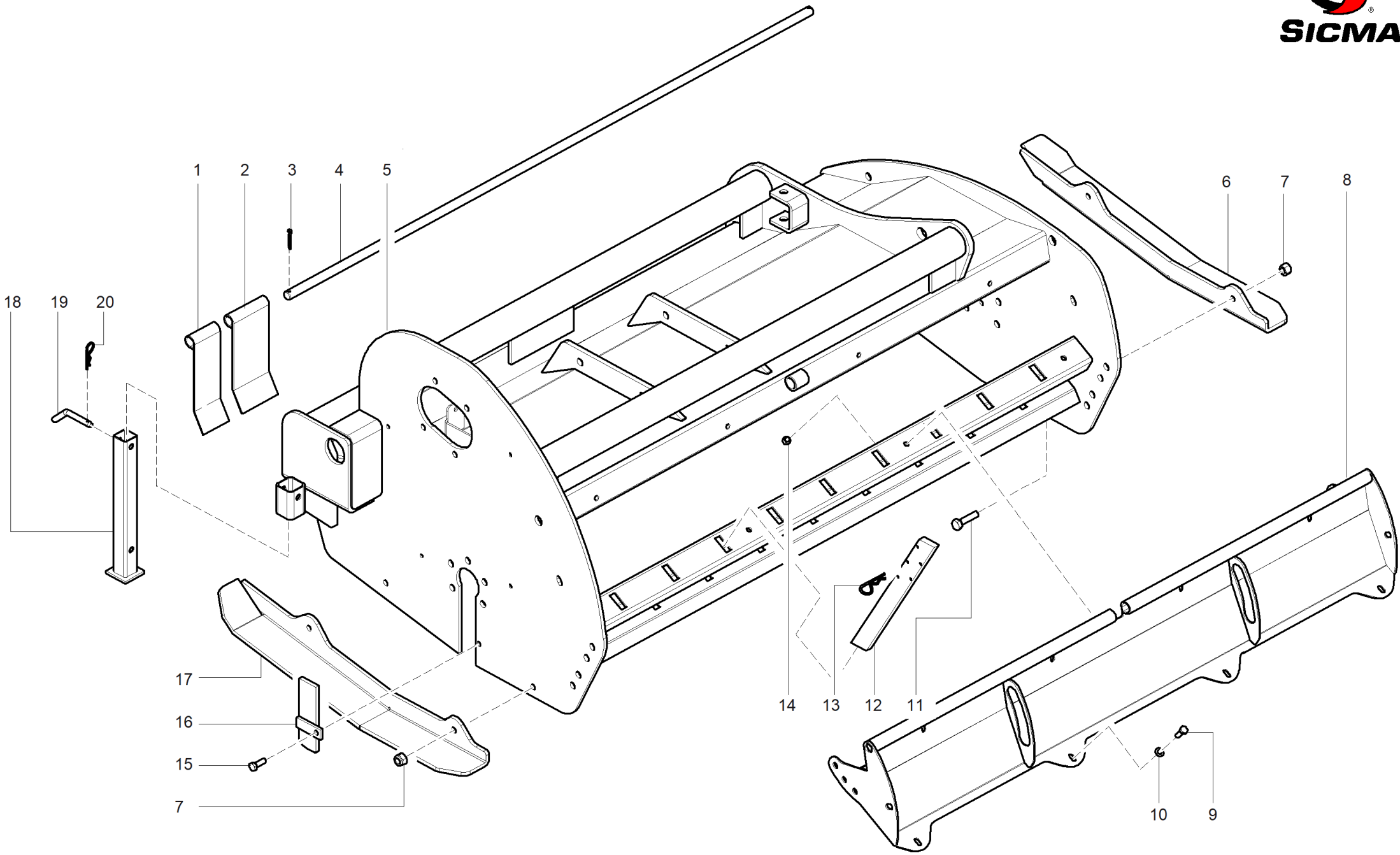

Machine type: SHREDDER

Model: TUF

Group: FRAME AND GUARDS

Document ID: 902621001

Revision: 02_09/02/2017 - 15/06/2019

Table: 05

Reference	P/N	Description	Model #	Quantity
1	5136104	175x55x40 TZF protection pallet		1
2	5136103	175X55x110 protection pallet		1
3	6340550	Split pin UNI1336 5x50 Untreated		1
4	5236062	TS155 pallet pivot	TUF/155	1
4	5237001	TZF180 pallet pivot	TUF/180	1
4	5237002	TZF200 pallet pivot	TUF/200	1
4	5237003	TZF220 pallet pivot	TUF/220	1
4	5237004	TZF250 pallet pivot	TUF/250	1
5	5007401	Body	TUF/155	1
5	5007402	Body	TUF/180	1
5	5007403	Body	TUF/200	1
5	5007404	Body	TUF/220	1
5	5007405	Body	TUF/250	1
6	5137042	TZF right slide		1
7	3464101014	UNI7473 (coarse pitch) M14 zinc plated nut		1
8	5007415	Fixed lid	TUF/155	1
8	5007416	Fixed lid	TUF/180	1
8	5007417	Fixed lid	TUF/200	1
8	5007418	Fixed lid	TUF/220	1
8	5007419	Fixed lid	TUF/250	1
9	3021110020	Screw UNI5739 8.8 M10x20 galvanised (coarse pitch)		1
10	3614100010	Wide washer UNI6593 100Hv Øi10 galvanised		1
11	3021112035	Screw UNI5739 8.8 M12x35 galvanised (coarse pitch)		1
12	5836084	TUF/SL/TZF crampons		1
13	6351005	Split pin Ad R Ø5 galvanised		1
14	3464101012	UNI7473 (coarse pitch) M12 zinc plated nut		1
15	3021110030	Screw UNI5739 8.8 M10x30 galvanised (coarse pitch)		1
16	5007435	Transmission slot closure		1
17	5137043	TZF left slide		1
18	5007046	TZF support foot		1
19	4236115	SA/SB/CS/ZLL/RM foot locking pin		1
20	6351004	Split pin Ad R Ø4 galvanised		1

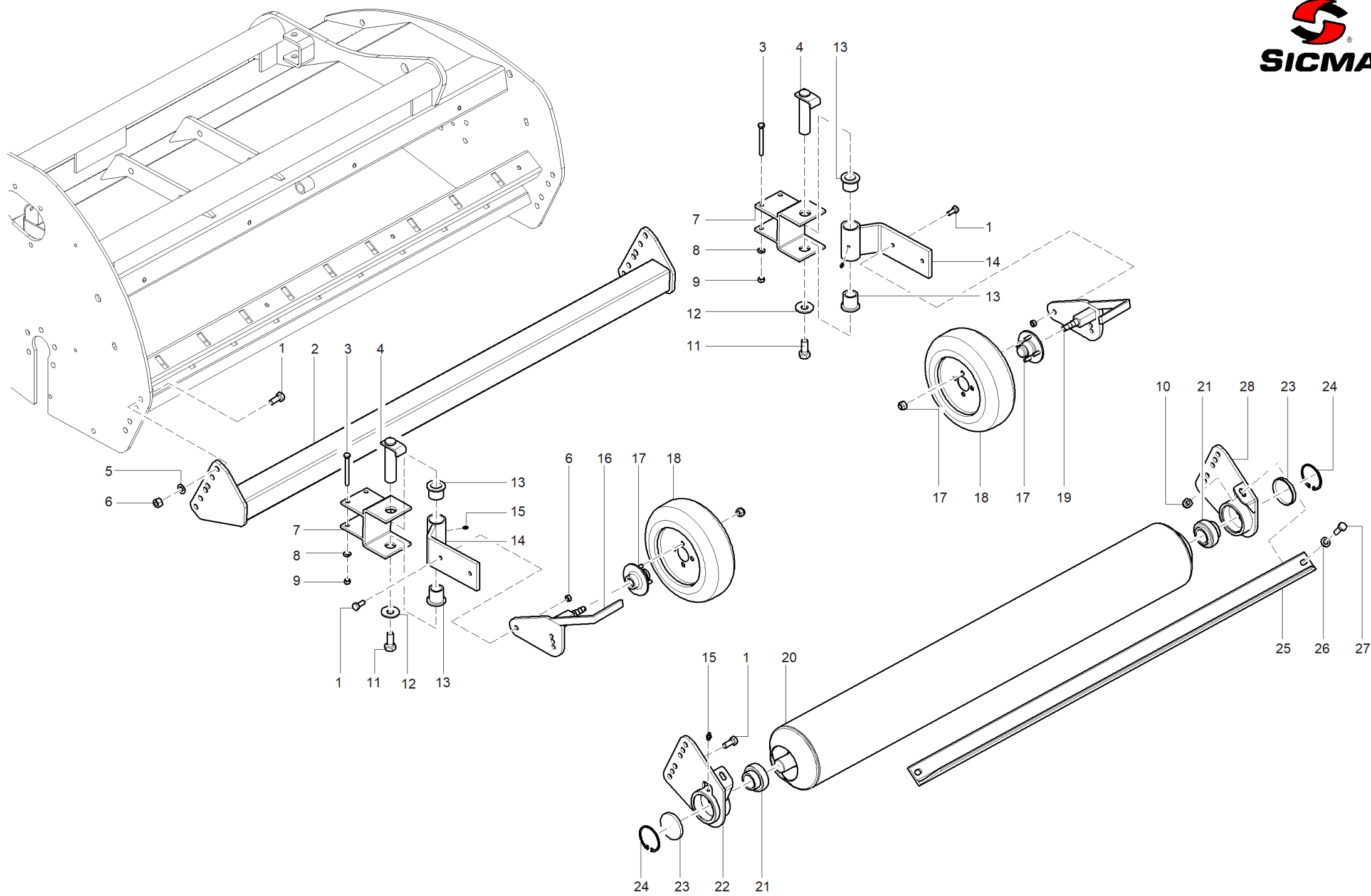

Machine type: SHREDDER

Document ID: 902621001

Model: TUF

Revision: 02_09/02/2017 - 15/06/2019

Group: REAR WHEELS AND ROLLER

Table: 06

Reference	P/N	Description	Model #	Quantity
1	3021114030	Screw UNI5739 8.8 M14x30 galvanised (coarse pitch)		1
2	5007445	TUF155 wheel support	TUF/155	1
2	5007446	TUF180 wheel support	TUF/180	1
2	5007447	TUF200 wheel support	TUF/200	1
2	5007448	TUF220 wheel support	TUF/220	1
2	5007449	TUF250 wheel support	TUF/250	1
3	3021110100	Screw TE M10x100 UN I5739		1
4	4005406	TS/TRX/TLX rotating pivot		1
5	341020014	Flat washer UNI6592 Ø14		1
6	3464101014	UNI7473 (coarse pitch) M14 zinc plated nut		1
7	4005390	TS/TRX junction support		1
8	341020010	Flat washer Ø10 UNI6592		1
9	3464101010	UNI7473 (coarse pitch) M10 zinc plated nut		1
10	3464101014	UNI7473 (coarse pitch) M14 zinc plated nut		1
11	3021114025	Screw TE M14x25 UNI5739		1
12	34118114	Wide washer UNI6593		1
13	5706890	Pivoting wheel sintered bushing		1
14	4005335	Wheel support boom		1
15	6560008	Type-A greaser UNI7663 M8x1.25		1
16	4005336	Lh wheel support		1
17	5846882	Complete 35 panel 4-hole spring		1
18	6610500	Wheel 145-10 6 tele Ø490		1
19	4005337	Rh wheel support		1
20	5007025	TUF/TZF180 stabilising roller	TUF/180	1
20	5007026	TUF/TZF200 stabilising roller	TUF/200	1
20	5007027	TUF/TZF220 stabilising roller	TUF/220	1
20	5007028	TUF/TZF250 stabilising roller	TUF/250	1
20	5007442	TUF155 stabilising roller	TUF/155	1
21	2030040	UC208 bearing		1
22	5007048	Left support roller TUF/TZF		1
23	6100080	Locking screw cap, Ø80 H=10		1
24	6311080	Ø80 SB internal ring		1
25	5857001	TZF180 roller scraper	TUF/180	1
25	5857002	TZF200 roller scraper	TUF/200	1
25	5857003	TZF220 roller scraper	TUF/220	1
25	5857004	TZF250 roller scraper	TUF/250	1
25	5857401	TUF155 roller scraper	TUF/155	1
26	3614100014	Wide washer UNI6593 100Hv Øi14 galvanised		1
27	3021114035	Screw UNI5739 8.8 M14x35 galvanised (coarse pitch)		1
28	5007049	TZF Rh roller support		1

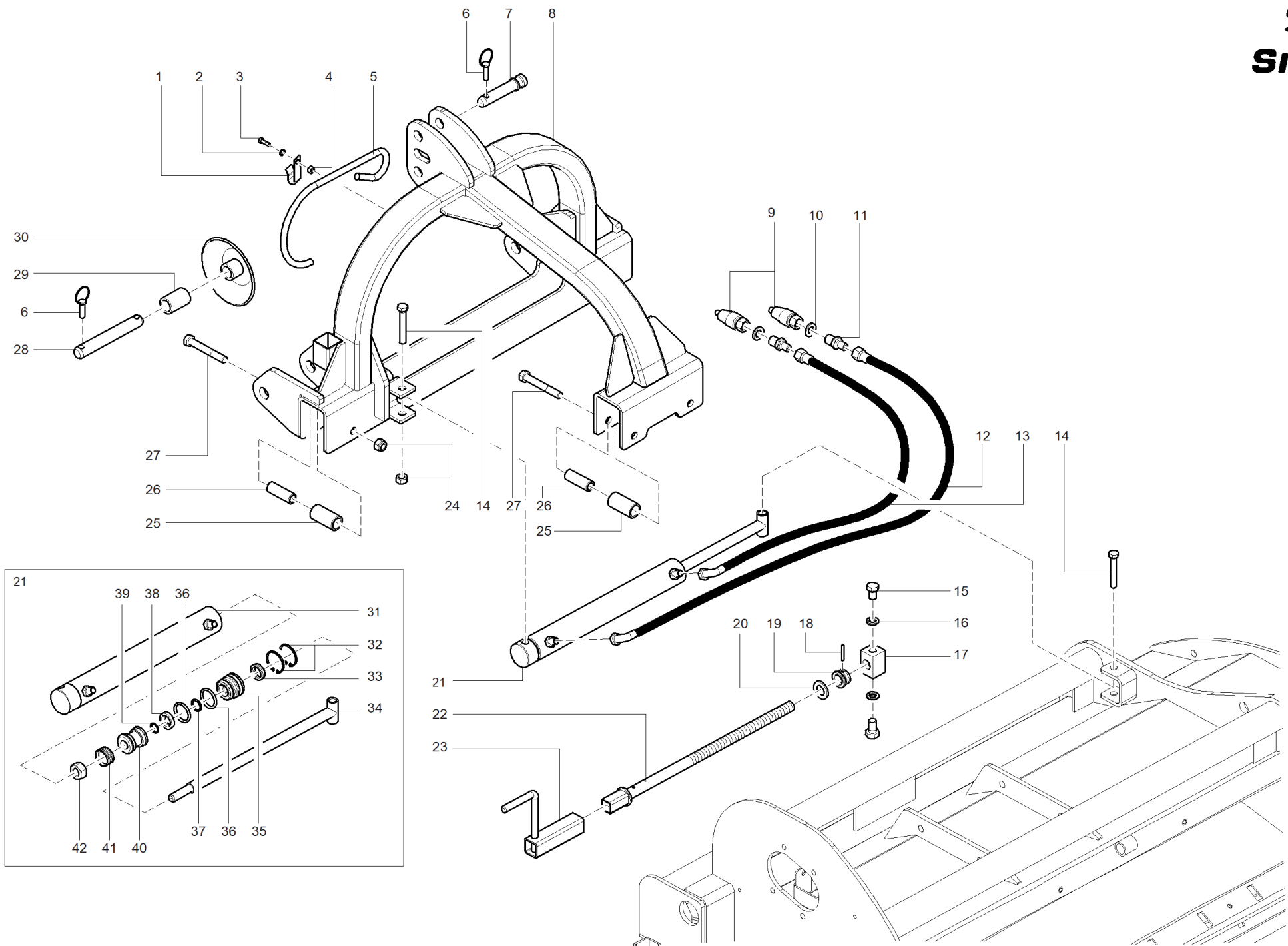

Machine type: SHREDDER

Document ID: 902621001

Model: TUF

Revision: 01_07/02/2015 - 08/02/2017

Group: Tractor hitches

Table: 01

Reference	P/N	Description	Model #	Quantity
1	5137068	RC/SA coupling support hook clip		1
2	361410008	Wide washer UNI6593 100Hv Øi08 galvanised		1
3	3021108016	Screw UNI5739 8.8 M8x16 galvanised (coarse pitch)		1
4	3464101008	UNI7473 (coarse pitch) M8 zinc plated nut		1
5	4337002	200 hook for shaft drive		1
6	6350010	Snap pin DIN11023 D10 galvanised		1
7	5304435	SPR/TRG/TR 3rd point pin Ø25		1
8	5007422	Mobile arc		1
9	6037683	Male quick-hitch 1/2"		1
10	6470012	Washer Cu 1/2		1
11	6037390	Nipple 1/2" 3/8"		1
12	6492250	Rubber hose R1-3/8 C/Md-2500		1
13	6492200	Rubber hose R1-3/8 C/Md-2000		1
14	3011116100	Screw UNI5737 8.8 M16x100 galvanised (coarse pitch)		1
15	3021116025	Screw UNI5739 8.8 M16x25 galvanised (coarse pitch)		1
16	3635100016	Grower Fiat washer 10188 C70 Ø16 zinc plated		1
17	5336326	TRX/TR/TUF moving scroll		1
18	6330640	Elastic pin Ø6x40 UNI6873 galvanised		1
19	5206324	Lateral moving bushing		1
20	3604100024	Flat washer M24 UNI6592		1
21	5007436	370 TUF stroke piston	TUF/155/180	1
21	5007437	450 TUF stroke piston	TUF/200/220/250	1
22	4002473	Screw for movement	TUF/155	1
22	4002474	Screw for movement	TUF/180	1
22	4002475	M24x3 screw SD185 moving	TUF/200/220/250	1
23	4002235	SD/TUF/TRX crank		1
24	3424101016	UNI5588 M16 (coarse pitch) zinc plated nut		1
25	5534080	FB/TZF external spacer tube		1
26	5534081	FB/TZF internal spacer tube		1
27	3011116110	Screw UNI5737 8.8 M16x110 galvanised (coarse pitch)		1
28	5304073	FB/TZF lower pin Cat.2		1
29	5534002	FB/TZF short spacer tube		1
30	5004034	FB/TZF bout cup		1
31	5007438	TUF155/180 piston jacket		1
32	5007439	TUF200/220/250 piston jacket		1
32	6310053	Elastic ring Ø53 UNI7437 DIN472		1
33	6038325	WRM 098129 scraper		1
34	5007440	Piston rod		1
35	5242372	FL10E/15E/-ETS/SD/.../TRX bearing holder ring		1
36	6836827	O-ring 617 2,62x17,86		1
37	6836120	O-ring 2,62x25x30		1
38	6838029	Gasket B129098/1		1
39	6836617	O-ring 617 2,62x17,86		1
40	5202373	TR/FB/TSP/TRX piston		1
41	6838283	Gasket DBM196133		1
42	3424101018	Nut M18 UNI5588		1

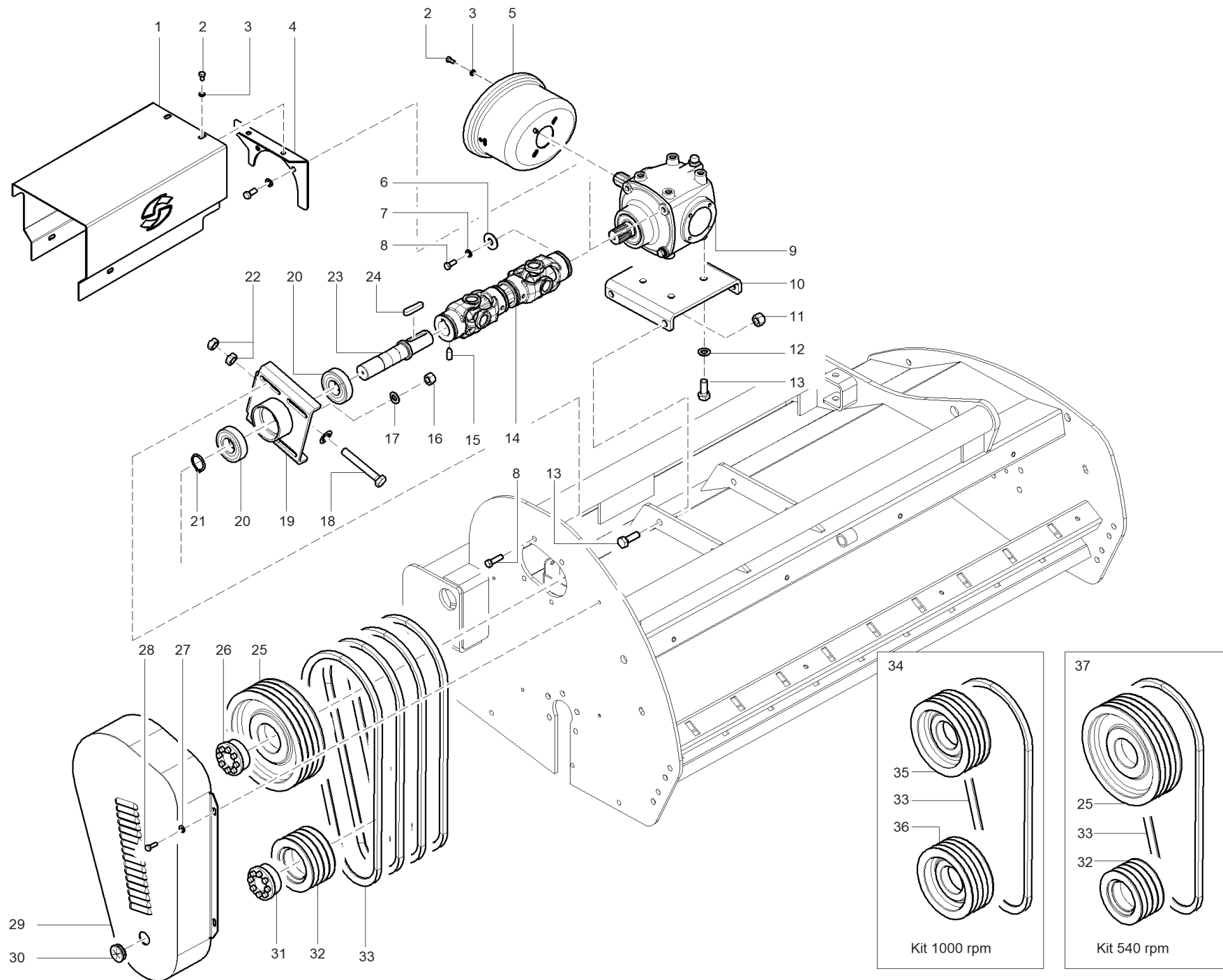

Machine type: SHREDDER

Document ID: 902621001

Model: TUF

Revision: 01_07/02/2015 - 08/02/2017

Group: SIDE TRANSMISSION

Table: 02

Reference	P/N	Description	Model #	Quantity
1	5137457	Drive shaft guard	TUF/155	1
1	5137458	Drive shaft guard	TUF/180	1
1	5137459	Drive shaft guard	TUF/200•220•250	1
2	3021108016	Screw UNI5739 8.8 M8x16 galvanised (coarse pitch)		1
3	3614100008	Wide washer UNI6593 100Hv Øi08 galvanised		1
4	5137460	Unit side transmission shaft guard support		1
5	1883512	Counter-cone		1
6	1201065	FB blocking washer		1
7	3625100012	Grower washer DIN1751 C70 Øi12 zinc plated		1
8	3021112030	Screw UNI5739 8.8 M12x30 galvanised (coarse pitch)		1
9	8060001	EC60 R.2/1 1/PTO+free wheel gearbox		1
10	5937413	Multiplier support plate		1
11	3464101016	UNI7473 (coarse pitch) M16 zinc plated nut		1
12	3604100016	Flat washer UNI6592 140Hv Øi16 galvanised		1
13	3021116035	Screw TE M16x35 UNI5739		1
14	E7255000	Driveshaft AX5F 320/506 1705111-1065015 SP		1
14	E7255006	Driveshaft AX5F 370/556 1705111-1065015 SP		1
14	EAX55000-0049	Driveshaft AX5F 220/406 1705111-1065015 SP		1
15	31112020	Grub screw 12X20 coarse pitch UNI5927		1
16	3464101012	UNI7473 (coarse pitch) M12 zinc plated nut		1
17	3614100012	Wide washer UNI6593 100Hv Øi12 galvanised		1
18	3011114110	Screw TE UNI5737 M14x110		1
19	5004400	TRG/TR driving pulley support		1
20	2226308	6308 2RS bearing		1
21	6320040	Elastic ring Ø40 UNI7435 DIN471		1
22	3464101014	UNI7473 (coarse pitch) M14 zinc plated nut		1
23	5214167	FB/TR driving pulley shaft		1
24	6361270	12x70x8 UNI6604 key		1
25	5643005	Pulley vibik spb 300/4 grooves		1
26	6364080	VK 156 40/80 shrink disc		1
27	3021108025	Screw UNI5739 8.8 M8x25 galvanised (coarse pitch)		1
28	3021108025	Screw UNI5739 8.8 M8x25 galvanised (coarse pitch)		1
29	5007434	TUF belt crankcase		1
30	6603516	Ø35x16 cap with opening for greaser		1
31	6364580	VK 156 45/80 shrink disc		1
32	5644132	Vibik spb 140/4 grooves		1
33	6721500	XPB-1500 toothed belt		1
34	8621021	Drive kit @1000rpm		1
35	5645103	Pulley vibik spb 236x4 Ø80		1
36	5644143	Pulley vibik spb 212/4 grooves (1000 rpm)		1
37	8621020	Drive kit @540rpm		1

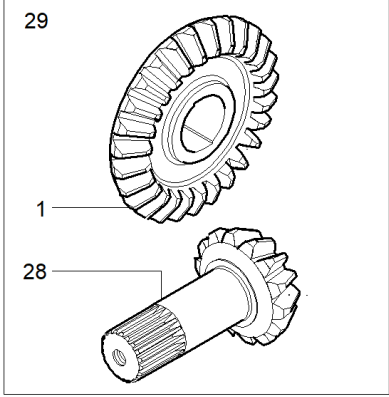
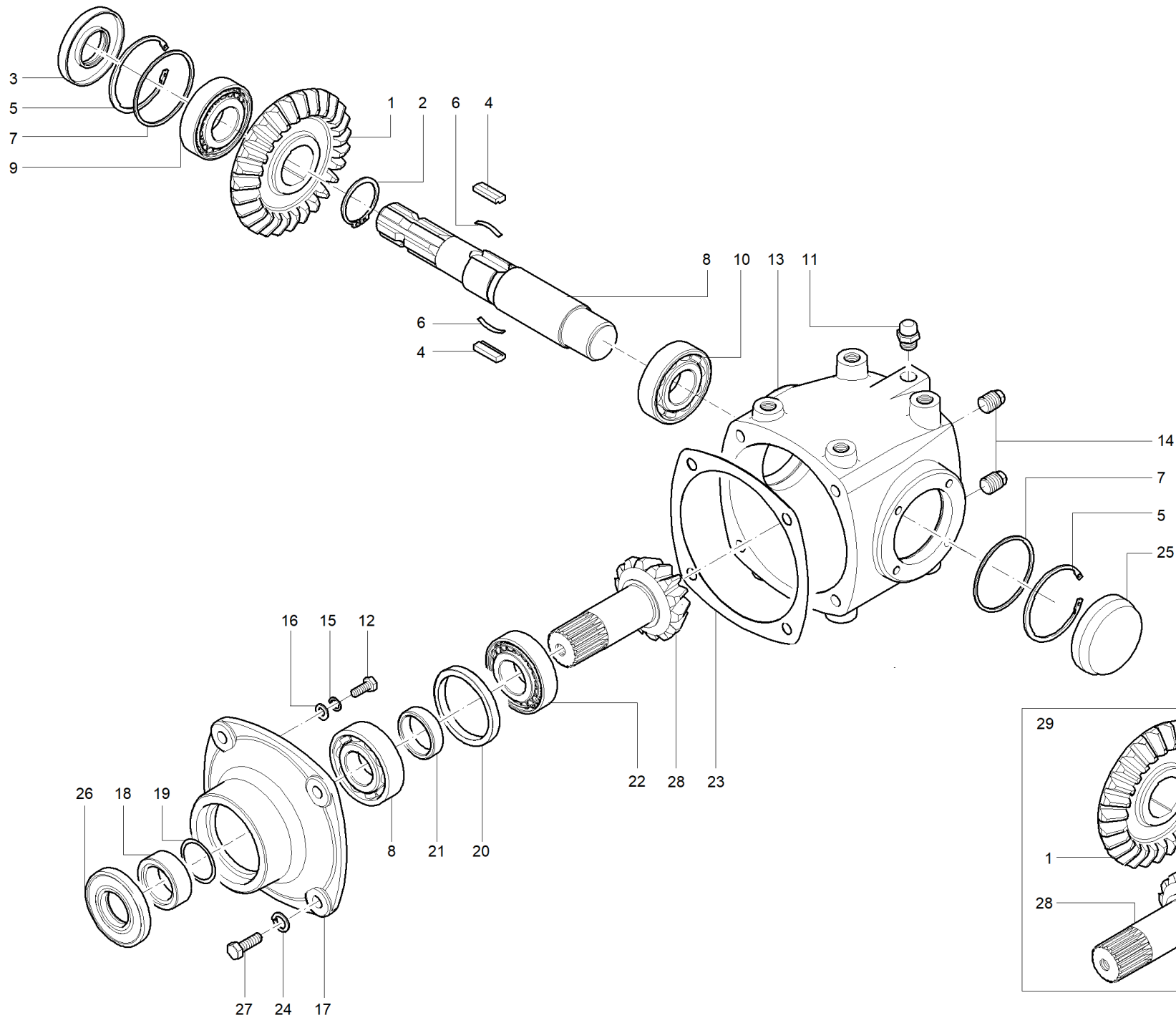

Machine type: SHREDDER

Model: TUF

Group: GEARBOX

Document ID: 902621001

Revision: 01_07/02/2015 - 08/02/2017

Table: 03

Reference	P/N	Description	Model #	Quantity
1	1721076	Z27 conical crown TUF/TR free wheel		1
2	6320042	Elastic ring Ø42 UNI7435 DIN471		1
3	6103580	35x80x12 GM DIN3760 A-type oil seal		1
4	1321001	EC60 free wheel stud		1
5	6310080	Elastic ring Ø80 UNI7437 DIN472		1
6	1811001	Flat spring		1
7	6017002	70x80x0,2 shim		1
8	1221003	Freewheel extension shaft		1
9	2030307	30307 bearing		1
10	2006208	6208 bearing		1
11	3442018	18X1.5 cylindrical valve cap		1
12	30208025	Screw TE M8x25 UNI5739		1
13	1641001	EC60 gearbox crankcase		1
14	3441018	18x1.5 conical cap (hexagon socket)		1
15	3625100008	Grower washer DIN1751 C70 Øi8 zinc plated		1
16	3604100008	Flat washer UNI6592 140Hv Øi08 galvanised		1
17	1701066	FB/TR sprocket support		1
18	1591073	OR824 door spacer		1
19	6836824	O-ring seal 824 D36,69x3,53		1
20	1591068	External ring bearing spacer		1
21	4593020	VM/ZLS connecting rod end oil seal bushing		1
22	2730208	30208 bearing		1
23	1781041	EC60 crankcase seal		1
24	3625100012	Grower washer DIN1751 C70 Øi12 zinc plated		1
25	6100080	Locking screw cap, Ø80 H=10		1
26	6106085	Oil seal 60x85x10 lawnmower DIN3760, A type		1
27	3021112030	Screw UNI5739 8.8 M12x30 galvanised (coarse pitch)		1
28	1721074	Z14 TUF/TR conical sprocket		1
29	8020012	EC60 bevel gear kit R.2:1 for free wheel		1

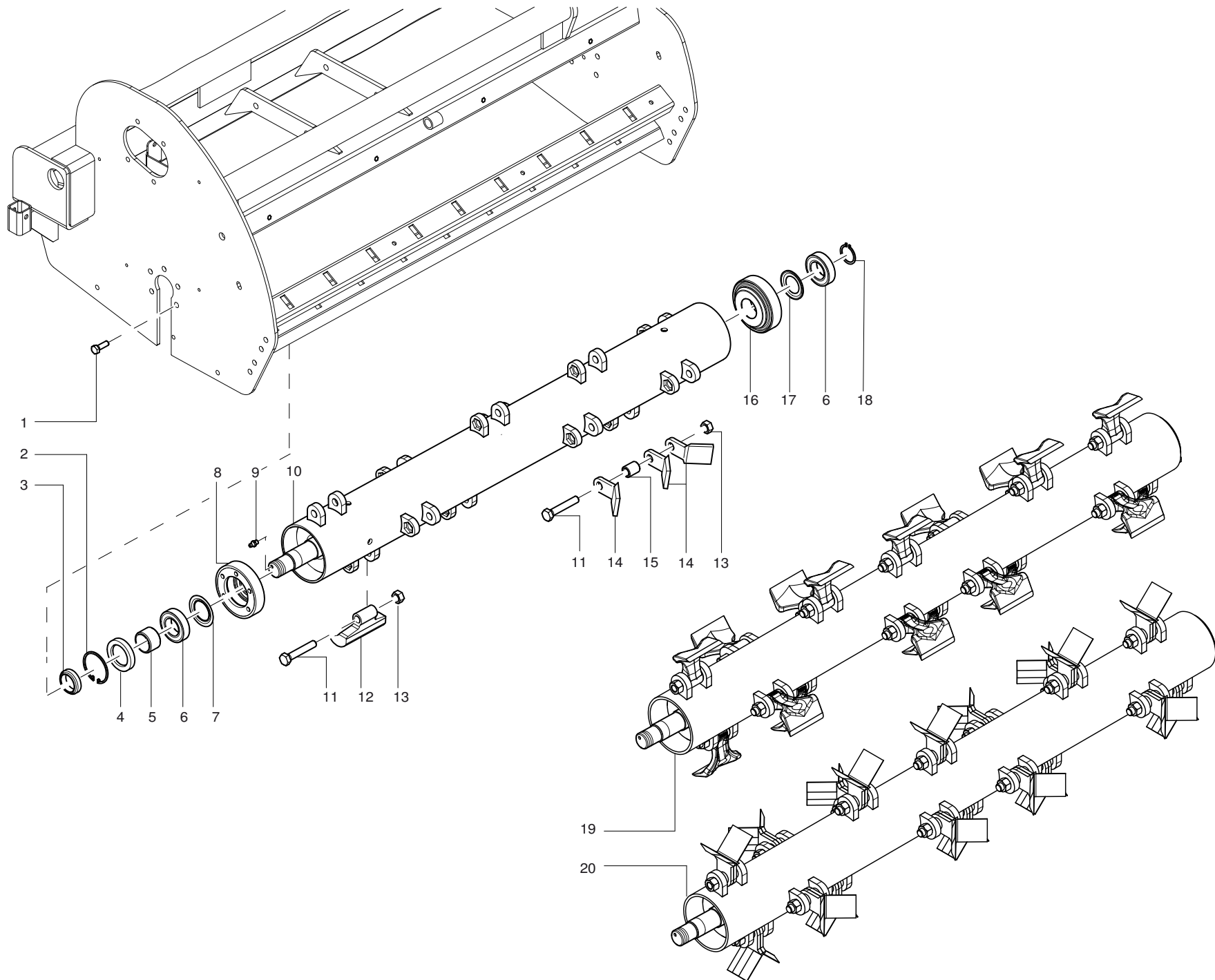

Machine type: SHREDDER

Document ID: 902621001

Model: TUF

Revision: 01 _07/02/2015 - 08/02/2017

Group: ROTOR AND TOOLS

Table: 04

Reference	P/N	Description	Model #	Quantity
17	2022210	22210/AV Nilos		1
7	2122210	22210/JV Nilos		1
6	2822210	22210 bearing		1
11	3011020120	TE UNI 5737 screw, coarse pitch 8.8 M20x120		1
1	3021114035	Screw UNI5739 8.8 M14x35 galvanised (coarse pitch)		1
3	34127050	50x1.5 high self-locking ring		1
13	3464101020	UNI7473 (coarse pitch) M20 zinc plated nut		1
10	5007425	TUF155 rotor	TUF/155	1
20	5007425C	TUF155 balanced rotor with knives	TUF/155	1
19	5007425ML	TUF155 balanced rotor with smooth hammers	TUF/155	1
10	5007426	TUF180 rotor	TUF/180	1
20	5007426C	TUF180 balanced rotor with knives	TUF/180	1
19	5007426ML	TUF180 balanced rotor with smooth hammers	TUF/180	1
10	5007427	TUF200 rotor	TUF/200	1
20	5007427C	TUF200 balanced rotor with knives	TUF/200	1
19	5007427ML	TUF200 balanced rotor with smooth hammers	TUF/200	1
10	5007428	TUF220 rotor	TUF/220	1
20	5007428C	TUF220 balanced rotor with knives	TUF/220	1
19	5007428ML	TUF220 balanced rotor with smooth hammers	TUF/220	1
10	5007429	TUF250 rotor	TUF/250	1
20	5007429C	TUF250 balanced rotor with knives	TUF/250	1
19	5007429ML	TUF250 balanced rotor with smooth hammers	TUF/250	1
8	5007443	TUF transmission side rotor support		1
16	5007444	TUF external side rotor support		1
15	5536275	FB/TUF knife spacer bushing		1
5	5536510	Ø60 L=38 TR/TZF duct pulley spacer		1
12	5715104S	RM Ø85 SL/SL-Q/TSN/TSN-Q/FB/TUF trip hammer (in 10x box)	TUF/220: 18 pc	18
12	5715104S	RM Ø85 SL/SL-Q/TSN/TSN-Q/FB/TUF trip hammer (in 10x box)	TUF/250: 20 pc	20
12	5715104S	RM Ø85 SL/SL-Q/TSN/TSN-Q/FB/TUF trip hammer (in 10x box)	TUF/155: 12 pc	12
12	5715104S	RM Ø85 SL/SL-Q/TSN/TSN-Q/FB/TUF trip hammer (in 10x box)	TUF/200: 16 pc	16
12	5715104S	RM Ø85 SL/SL-Q/TSN/TSN-Q/FB/TUF trip hammer (in 10x box)	TUF/180: 14 pc	14
14	5816274S	"Y" TS/TSP/TSN/TZF/TUF/SL/FB knife (in 20x box)	TUF/250: 60 pc	60
14	5816274S	"Y" TS/TSP/TSN/TZF/TUF/SL/FB knife (in 20x box)	TUF/220: 54 pc	54
14	5816274S	"Y" TS/TSP/TSN/TZF/TUF/SL/FB knife (in 20x box)	TUF/200: 48 pc	48
14	5816274S	"Y" TS/TSP/TSN/TZF/TUF/SL/FB knife (in 20x box)	TUF/180: 42 pc	42
14	5816274S	"Y" TS/TSP/TSN/TZF/TUF/SL/FB knife (in 20x box)	TUF/155: 36 pc	36
4	6106090	Oil seal 60x90x10 lawnmower DIN3760, A type		1
2	6310090	Elastic ring Ø90 UNI7437 DIN472		1
18	6320050	Elastic ring Ø50 UNI7435 DIN471		1
9	6560010	Type-A greaser UNI7663 M10x1.5		1

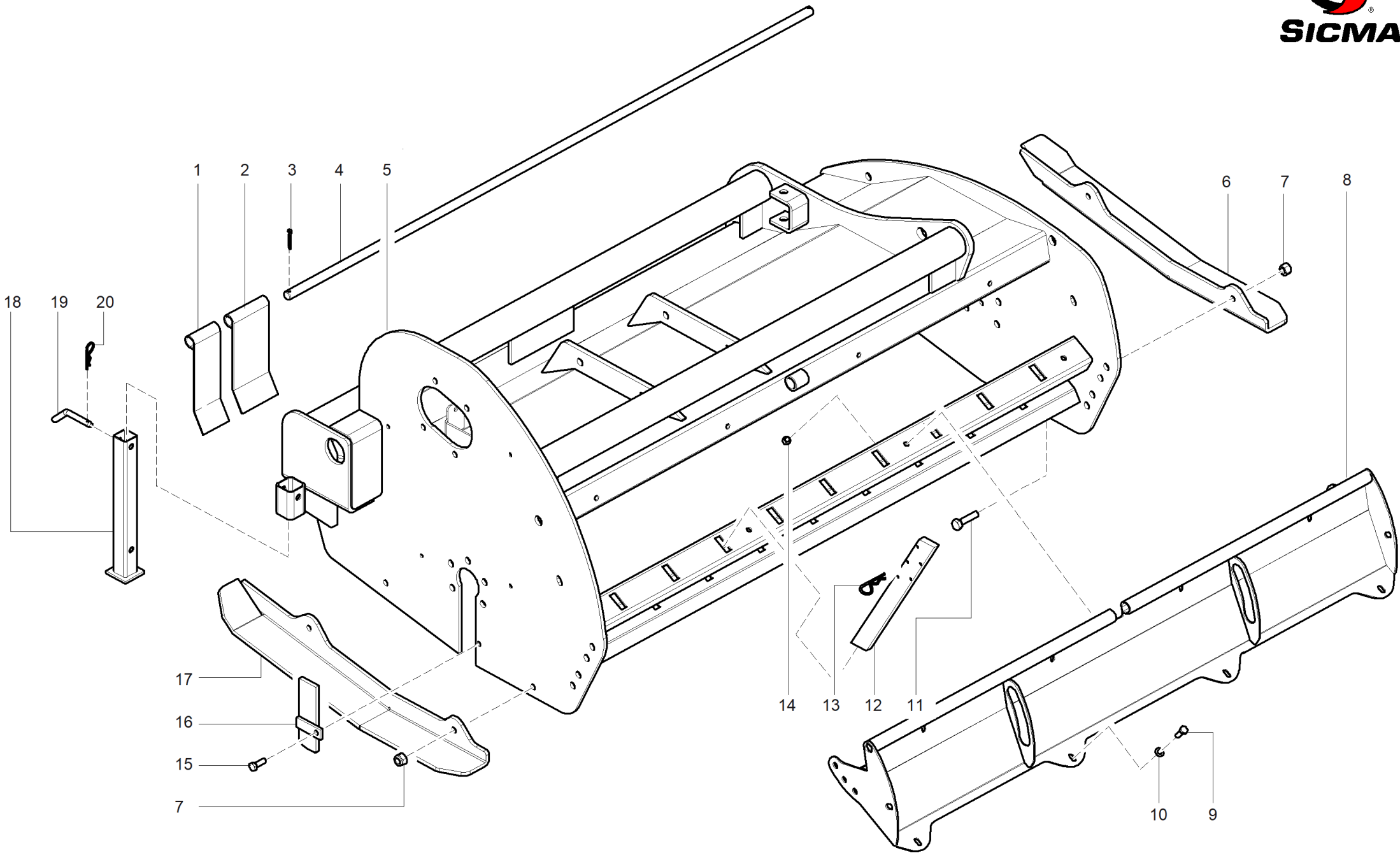

Machine type: SHREDDER

Model: TUF

Group: FRAME AND GUARDS

Document ID: 902621001

Revision: 01_07/02/2015 - 08/02/2017

Table: 05

Reference	P/N	Description	Model #	Quantity
1	5136104	175x55x40 TZF protection pallet		1
2	5136103	175X55x110 protection pallet		1
3	6340550	Split pin UNI1336 5x50 Untreated		1
4	5236062	TS155 pallet pivot	TUF/155	1
4	5237001	TZF180 pallet pivot	TUF/180	1
4	5237002	TZF200 pallet pivot	TUF/200	1
4	5237003	TZF220 pallet pivot	TUF/220	1
4	5237004	TZF250 pallet pivot	TUF/250	1
5	5007401	Body	TUF/155	1
5	5007402	Body	TUF/180	1
5	5007403	Body	TUF/200	1
5	5007404	Body	TUF/220	1
5	5007405	Body	TUF/250	1
6	5137042	TZF right slide		1
7	3464101014	UNI7473 (coarse pitch) M14 zinc plated nut		1
8	5007415	Fixed lid	TUF/155	1
8	5007416	Fixed lid	TUF/180	1
8	5007417	Fixed lid	TUF/200	1
8	5007418	Fixed lid	TUF/220	1
8	5007419	Fixed lid	TUF/250	1
9	3021110020	Screw UNI5739 8.8 M10x20 galvanised (coarse pitch)		1
10	3614100010	Wide washer UNI6593 100Hv Øi10 galvanised		1
11	3021112035	Screw UNI5739 8.8 M12x35 galvanised (coarse pitch)		1
12	5836084	TUF/SL/TZF crampons		1
13	6351005	Split pin Ad R Ø5 galvanised		1
14	3464101012	UNI7473 (coarse pitch) M12 zinc plated nut		1
15	3021110030	Screw UNI5739 8.8 M10x30 galvanised (coarse pitch)		1
16	5007435	Transmission slot closure		1
17	5137043	TZF left slide		1
18	5007046	TZF support foot		1
19	4236115	SA/SB/CS/ZLL/RM foot locking pin		1
20	6351004	Split pin Ad R Ø4 galvanised		1

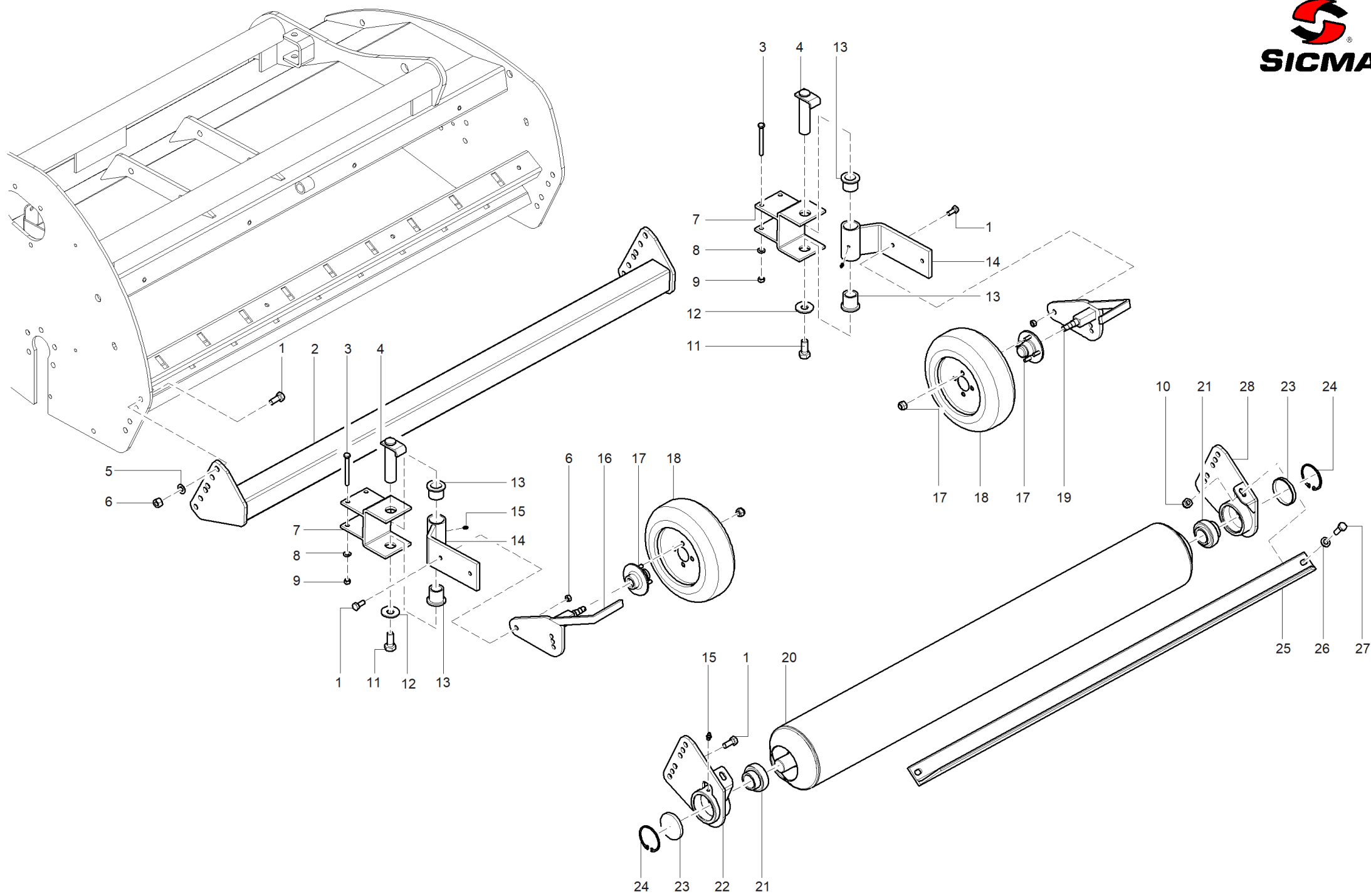

Machine type: SHREDDER

Document ID: 902621001

Model: TUF

Revision: 01_07/02/2015 - 08/02/2017

Group: REAR WHEELS AND ROLLER

Table: 06

Reference	P/N	Description	Model #	Quantity
1	3021114030	Screw UNI5739 8.8 M14x30 galvanised (coarse pitch)		1
2	5007445	TUF155 wheel support	TUF/155	1
2	5007446	TUF180 wheel support	TUF/180	1
2	5007447	TUF200 wheel support	TUF/200	1
2	5007448	TUF220 wheel support	TUF/220	1
2	5007449	TUF250 wheel support	TUF/250	1
3	3021110100	Screw TE M10x100 UN I5739		1
4	4005406	TS/TRX/TLX rotating pivot		1
5	341020014	Flat washer UNI6592 Ø14		1
6	3464101014	UNI7473 (coarse pitch) M14 zinc plated nut		1
7	4005390	TS/TRX junction support		1
8	341020010	Flat washer Ø10 UNI6592		1
9	3464101010	UNI7473 (coarse pitch) M10 zinc plated nut		1
10	3464101014	UNI7473 (coarse pitch) M14 zinc plated nut		1
11	3021114025	Screw TE M14x25 UNI5739		1
12	34118114	Wide washer UNI6593		1
13	5706890	Pivoting wheel sintered bushing		1
14	4005335	Wheel support boom		1
15	6560008	Type-A greaser UNI7663 M8x1.25		1
16	4005336	Lh wheel support		1
17	5846882	Complete 35 panel 4-hole spring		1
18	6610500	Wheel 145-10 6 tele Ø490		1
19	4005337	Rh wheel support		1
20	5007025	TUF/TZF180 stabilising roller	TUF/180	1
20	5007026	TUF/TZF200 stabilising roller	TUF/200	1
20	5007027	TUF/TZF220 stabilising roller	TUF/220	1
20	5007028	TUF/TZF250 stabilising roller	TUF/250	1
20	5007442	TUF155 stabilising roller	TUF/155	1
21	2030040	UC208 bearing		1
22	5007048	Left support roller TUF/TZF		1
23	6100080	Locking screw cap, Ø80 H=10		1
24	6311080	Ø80 SB internal ring		1
25	5857001	TZF180 roller scraper	TUF/180	1
25	5857002	TZF200 roller scraper	TUF/200	1
25	5857003	TZF220 roller scraper	TUF/220	1
25	5857004	TZF250 roller scraper	TUF/250	1
25	5857401	TUF155 roller scraper	TUF/155	1
26	3614100014	Wide washer UNI6593 100Hv Øi14 galvanised		1
27	3021114035	Screw UNI5739 8.8 M14x35 galvanised (coarse pitch)		1
28	5007049	TZF Rh roller support		1