

NANNING TAGRM CO., LTD

Tel : 86-771-5384871

Fax : 86-771-5384371

Add:NO.399 Wuxiang Avenue Liangqing District Nanning Guangxi China 530000

E-mail:tagrm128@tagrm.com

Mobile:86-15277715440

M2000 COMPOST TURNER



WITHOUT CABIN



WITH CABIN

NANNING TAGRM CO., LTD

Tel : 86-771-5384871

Fax : 86-771-5384371

Address: NO.399 Wuxiang Avenue Liangqing District Nanning Guangxi China 530000

E-mail: tagrm128@tagrm.com

Mobile: 86-15277715440

Features

400-500 cubic meter/hr, the same of 100 workers labour, it can produce 160-200 tons compound fertilizer. Suggest to small fertilizer plant which the yearly capacity 10000-30000ton.

Main technical specifications

Model	M2000		Ground clearance	130mm	H2
Rate Power	44KW (60PS)		Ground pressure	0.46Kg/cm ²	
Rate speed	2200r/min		Working width	2000mm	W1
Fuel consumption	≤225g/KW·h		Working height	800mm	Max.
Battery	24V	2×12V	Pile shape	Triangle	45°
Fuel capacity	40L		Forward speed	L: 0-8m/min H: 0-40m/min	
Wheel tread	2350mm	W2	Rear speed	L: 0-8m/min H: 0-40m/min	
Wheel base	1400mm	L1	Turning radius	2450mm	min
Oversize	2600×2140×2600mm	W3×L2×H1	Diameter of roller	580mm	With knife
Weight	1500kg	Without fuel	Working capacity	430m ³ /h	Max.

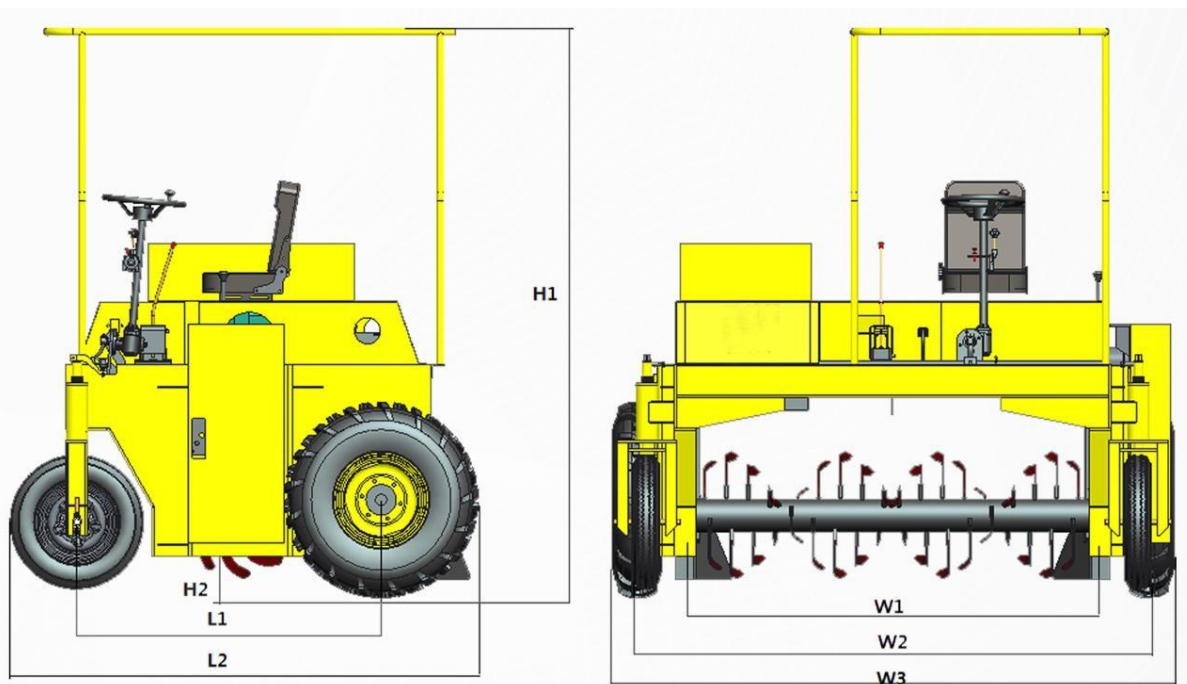

Payment terms: T/T50% advanced as deposit,50% before loading ship.

Delivery lead time: 30days

Load:2sets/20 Foot Container

3sets/40 Foot Container

Packing: Nude

Note: Cost of installation and technical support/training extra.

Products' picture and data just for reference, it will some different after developed.